

Wireless SDI2 bus interface

B812

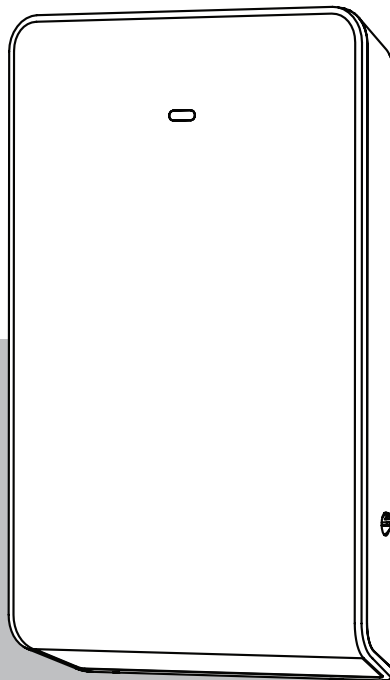

Table of contents

1	Safety	5
2	Introduction	6
2.1	About documentation	6
2.2	Bosch Security Systems B.V. product manufacturing dates	6
3	Regulatory information	7
3.1	Certifications and approvals	7
3.1.1	FCC	7
3.1.2	Industry Canada	7
3.1.3	CE	8
3.1.4	ANATEL	8
3.2	UL product requirements	8
3.2.1	RADION repeater (RFRP2)	8
3.2.2	RADION repeater (RFRP)	9
3.2.3	RADION glassbreak (RFGB)	9
3.2.4	RADION TriTech (RFDL-11)	9
3.2.5	RADION smoke (RFSM/RFSM2-A)	10
3.2.6	RADION contact SM (RFDW-SM)	10
3.2.7	RADION contact RM (RFDW-RM)	10
3.2.8	RADION specialty (bill trap/RFBT)	10
3.2.9	RADION universal transmitter (RFUN)	11
3.2.10	RADION keyfob (all RFKFs)	11
3.2.11	Battery reliability and testing	11
4	B812 Wireless SDI2 bus interface	12
4.1	Installation	12
4.1.1	Configuration	12
4.1.2	Base installation	13
4.1.3	Wiring considerations	13
4.1.4	Programming wireless points in the control panel	14
4.1.5	Enroll point RF ID for wireless points (Auto-learn mode)	16
4.1.6	Walk test (for motion detectors)	16
4.1.7	Signal level and margin	17
4.1.8	Complete the installation	18
4.1.9	B812 system test	18
4.2	External LED states	18
4.2.1	LEDs	19
4.3	Check-in intervals, power level, and regions for RADION devices	20
4.4	Specifications	22
4.4.1	Battery requirements	22
5	RADION repeater (RFRP/RFRP2)	24
5.1	RFRP2	24
5.1.1	Installation considerations	24
5.1.2	Redundant communication verification process	24
5.1.3	Specifications	25
5.1.4	LEDs	25
6	RADION glassbreak (RFGB)	27
6.1	Installation considerations	27
6.2	Testing	28
6.3	Low battery	29

6.4	Wall Tamper Tab	30
6.5	Maintenance	30
7	RADION TriTech (RFDL-11)	31
7.1	Mounting height and range adjustment	31
7.2	Sensitivity settings	32
7.3	Walk testing	32
8	RADION PIR (RFPR-12)	34
8.1	Walk testing	34
9	RADION PIR C (RFPR-C12)	36
9.1	Walk testing	36
10	RADION smoke (RFSM)	38
10.1	Battery replacement	39
10.2	Smoke test	39
10.3	Sensitivity test	39
10.4	Test/Silence button	40
10.5	LED	40
10.6	Clean the detector and replace the optical chamber	40
11	RADION smoke (RFSM2-A)	42
12	RADION contact SM (RFDW-SM)	43
12.1	Installation considerations	43
13	RADION contact RM (RFDW-RM)	45
13.1	Installation considerations	45
14	RADION specialty (bill trap/RFBT)	47
14.1	Applications for this product	48
14.2	Installation consideration	48
15	RADION universal transmitter (RFUN)	49
15.1	Installation considerations	50
15.2	Reed switch settings	51
16	RADION keyfob (all RKFf)	52
16.1	RADION keyfob FB (four button)	53
16.2	RADION keyfob TB (two button)	54
17	RADION panic (RFPB)	55
18	Appendices	57

1**Safety**

**Caution!**

Remove all power (AC and battery) before making any connections. Failure to do so might result in personal injury and/or equipment damage.

2 Introduction

This document contains the basic information that a trained installer needs to install the RADION system. It supplements the documents listed inside the packaging (graphical installation guides).

This installation manual contains:

- A description of the general installation procedure.
- Device-specific installation procedures.
- Specification information.

How to use this document

The information contained in this document is constructed in a manner that is systematic and sequential for the installer on a “point of need” basis;

- Chapter 1 - basic safety notice.
- Chapter 2 - introductory information and how to use this document.
- Chapter 3 - regulatory certification information.
- Chapter 4 - basic RADION system-wide general installation information and workflow check list.
- Remaining chapters - RADION device-specific installation information.
- Appendix - description of various icons and symbols used within the RADION documentation.

Icons and symbols

When you see the following logos in the RADION graphical installation guides, refer to the appropriate section in this manual for more information.

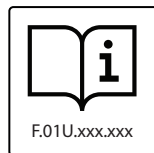

2.1 About documentation

Copyright

This document is the intellectual property of Bosch Security Systems B.V. and is protected by copyright. All rights reserved.

Trademarks

All hardware and software product names used in this document are likely to be registered trademarks and must be treated accordingly.

2.2 Bosch Security Systems B.V. product manufacturing dates

Manufacturing dates

For product manufacturing dates, go to <http://www.boschsecurity.com/datecodes/> and refer to the serial number located on the product label.

3 Regulatory information

3.1 Certifications and approvals

Listings and approvals

3.1.1 FCC

Federal Communications Commission (FCC) Rules

This device complies with part 15 of the FCC Rules. Operation is subject to the following two conditions: (1) This device may not cause harmful interference, and (2) this device must accept any interference received, including interference that may cause undesired operation.

This equipment has been tested and found to comply with the limits for a Class B digital device, pursuant to Part 15 of the FCC rules. These limits are designed to provide reasonable protection against harmful interference in a residential installation. This equipment generates, uses, and can radiate radio frequency energy and, if not installed and used in accordance with the instructions, may cause harmful interference to radio communications. However, there is no guarantee that interference will not occur in a particular installation. If this equipment does cause harmful interference to radio or television reception, which can be determined by turning the equipment off and on, the user is encouraged to try to correct the interference by one or more of the following:

- Reorient or relocate the receiving antenna.
- Increase the separation between the equipment and receiver.
- Connect the equipment into an outlet on a circuit different from that to which the receiver is connected.
- Consult the dealer or an experienced radio/TV technician for help.

3.1.2 Industry Canada

This device contains license-exempt transmitter(s)/receiver(s) that comply with Innovation, Science and Economic Development Canada's license-exempt RSS(s). Operation is subject to the following two conditions:

1. This device may not cause interference.
2. This device must accept any interference, including interference that may cause undesired operation of the device.

This device complies with the Canadian ICES-003 Class B specifications. CAN ICES-003(B) / NMB-003 (B).

L'émetteur/récepteur exempt de licence contenu dans le présent appareil est conforme aux CNR d'Innovation, Sciences et Développement économique Canada applicables aux appareils radio exempt de licence. L'exploitation est autorisée aux deux conditions suivantes :

1. L'appareil ne doit pas produire de brouillage;
2. L'appareil doit accepter tout brouillage radioélectrique subi, même si le brouillage est susceptible d'en compromettre le fonctionnement.

Cet appareil numérique de la classe B est conforme à la norme NMB-003 du Canada.

ISED/FCC RF Exposure statement

This equipment complies with FCC and ISED RSS-102 radiation exposure limits set forth for an uncontrolled environment. This transmitter must not be co-located or operating in conjunction with any other antenna or transmitter. In order to avoid the possibility of exceeding the FCC and ISED

RSS-102 radio frequency exposure limits, this equipment should be installed and operated with minimum distance 20 cm (7.9 inches) between the antenna and your body during normal operation. Users must follow the specific operating instructions for satisfying RF exposure compliance. Cet équipement est conforme aux limites d'exposition aux rayonnements FCC et ISED CNR-102 établies pour un environnement non contrôlé. Cet émetteur ne doit pas être installé ou utilisé en conjonction avec une autre antenne ou un autre émetteur. Afin d'éviter la possibilité de dépasser les limites d'exposition aux radiofréquences FCC et ISED, cet équipement doit être installé et utilisé avec une distance minimale de 20 cm (7.9 pouces) entre l'antenne et votre corps pendant le fonctionnement normal. Les utilisateurs doivent suivre les instructions spécifiques d'utilisation pour respecter la conformité à l'exposition aux RF.

3.1.3

CE

This device complies with Directive 93/68/EEC Compliance.

3.1.4

ANATEL

Este equipamento não tem direito à proteção contra interferência prejudicial e não pode causar interferência em sistemas devidamente autorizados". Dans le but de réduire les risques de brouillage radioélectrique à l'intention des autres utilisateurs, il faut choisir le type d'antenne et son gain de sorte que la puissance isotrope rayonnée équivalente (p.i.r.e.) ne dépasse pas l'intensité nécessaire à l'établissement d'une communication satisfaisante.

3.2

UL product requirements

This device is UL listed for Commercial/Residential Burglar Alarm Systems, and Household Fire Warning System Units.



Notice!

For all wireless devices, receivers, and/or repeaters, do not install on removable surfaces such as ceiling tiles.

For product-specific UL requirements, refer to desired product title below for more information.

3.2.1

RADION repeater (RFRP2)



Notice!

RFRP2 battery
The battery for the RFRP2 is not user replaceable.



Notice!

Globtek power supply
The Globtek power supply is not evaluated by UL.



Notice!

UL system compliance
For UL system compliance the RFRP2 shall be connected to a UL Listed Residential Fire/UL Residential Burg/ Commercial Burglar Alarm power supply with a class 2 power limited output with a voltage range of 10-14VDC , (nominal)1 Amp @12VDC Max.

3.2.2 RADION repeater (RFRP)

When selecting a suitable 16.5 VAC Class 2 plug in transformer, the following transformers are suggested:

- MG Electronics (MGT-1640)
- Codex SEP-1640

The transformers mentioned above are Primary Rated 120 VAC, 60 Hz, 0.48 Amps, Secondary 16.5 VAC, 40 VA.

When selecting a suitable 18 VAC Class 2 plug-in transformer, the following transformers are suggested:

- TDC Part No DA-22-18, Primary Rated 120 VAC, 60 Hz, 30 VA, Secondary Rated 18 VAC, 1.22 Amps, 22 VA.



Notice!

For UL installations when transformer is used, restraining tab is to be connected.



Notice!

For UL installations when used in a life safety application (such as in a fire warning system), at least two repeaters must be used to provide redundant communication paths. Perform the Redundant Verification Process.

Information related to the internal standby battery is as follows:

- Power/voltage (Standby Battery): Rated 3.7 VDC, 3050mAh, EVE ENERGY CO Part No P0046-LF (Not user replaceable)



Notice!

For standby battery to be operative, the tamper switch is required to be engaged. The standby battery is designed to last for the lifetime of the product.

Standby battery is capable of providing 72 hours of standby power to the RF repeater for a UL Burglar Alarm Installation (Bank Safe and Vault).

- 24 Hours for Household Fire Warning Systems
- 8 Hours for HOLD UP Burglar Alarms
- 4 Hours for Burglar Alarm Mercantile Installations

3.2.3 RADION glassbreak (RFGB)



Notice!

The RFGB-A has not been investigated by UL, and not part of a UL Listed system.

3.2.4 RADION TriTech (RFDL-11)



Notice!

Pet Immunity has not been evaluated by UL.

**Notice!**

Draft and Insect Immunity has not been evaluated by UL.

3.2.5**RADION smoke (RFSM/RFSM2-A)**

For UL installations THIS UNIT INCLUDES AN ALARM VERIFICATION FEATURE THAT WILL RESULT IN A DELAY OF THE SYSTEM ALARM SIGNAL FROM THE INDICATED CIRCUITS. THE TOTAL DELAY (CONTROL UNIT PLUS SMOKE DETECTORS) SHALL NOT EXCEED 60 SECONDS. NO OTHER SMOKE DETECTOR SHALL BE CONNECTED TO THESE CIRCUITS UNLESS APPROVED BY THE LOCAL AUTHORITY HAVING JURISDICTION.

For CSFM installations, THIS UNIT INCLUDES AN ALARM VERIFICATION FEATURE THAT WILL RESULT IN A DELAY OF THE SYSTEM ALARM SIGNAL FROM THE INDICATED CIRCUITS. THE TOTAL DELAY (CONTROL UNIT PLUS SMOKE DETECTORS) SHALL NOT EXCEED 30 SECONDS. NO OTHER SMOKE DETECTOR SHALL BE CONNECTED TO THESE CIRCUITS UNLESS APPROVED BY THE LOCAL AUTHORITY HAVING JURISDICTION.

3.2.6**RADION contact SM (RFDW-SM)**

During the installation of the device, UL installations primary securement means shall be screws.

3.2.7**RADION contact RM (RFDW-RM)**

During the installation of the device, UL installations primary securement means shall be screws.

3.2.8**RADION specialty (bill trap/RFBT)****Notice!**

For the RFBT-A bill trap, UL requires the battery to be replaced annually to ensure optimal performance.

When programming the bill trap, special programming for a hold up device is required. Program the point as follows:

- P## Type = 2 (Point is constantly armed regardless of the status of the system).
- P## Invisible Point = Yes (Keypads do not display alarm activity from this point).

For UL installations, the RFBT-A shall be permanently mounted using the 3M VHB 4956 double sided adhesive tape. The suitable surfaces are:

- Aluminum
- Galvanized steel
- Stainless steel
- Enameled steel
- Nickel Coated ABS
- Glass (with or without Silane Coating)
- PVC
- Glass/Epoxy
- PBT
- Polycarbonate
- Acrylic/Polyurethane paint
- Polyester paint

3.2.9 **RADION universal transmitter (RFUN)**

During the installation of the device, the following items are required by UL:

- For UL installations, an UL Listed burglar alarm dry contact device shall be connected if the external terminal is used.
- When external contact, such as the ISC-PB1-100, is configured for UL hold up installations, a hold up device such as potter electric model HUB is to be connected to the external contact. For programming, refer to the appropriate control panel manual “Special programming required for a hold up device.” Point shall be programmed as stated below:
 - P## Type = 1 Instant on open or short (Point is constantly armed regardless of the status of the system).
 - P## Invisible Point/Silent Bell = Yes (Keypads do not display alarm activity from this point).

Furthermore for UL hold up installations the internal reed switch is to be disabled. The door window contact magnet will not be operative. The transmitter if used for hold up installations shall be dedicated to a holdup installation only. Hold up alarm requires a UL Listed Automation System at the Central Station to show distinction between a Hold Up Alarm and a regular Burglar Alarm.

- For UL installations, a 2.2 K ohm shall be installed.
- For UL installations, primary securement means shall be screws.

3.2.10 **RADION keyfob (all RFKFs)**

To comply with UL 1023, RADION keyfobs shall be programmed with Forced Arm Bypass Max set to 0.

3.2.11 **Battery reliability and testing**

UL battery requirements

UL recommends to check the battery of each device annually. This will ensure proper operation and functionality of the devices.

Battery testing

To ensure proper functionality of each RADION device, it is recommended to test your batteries annually via your supported control panels wireless diagnostics routine. For specific information related to system diagnostics and battery testing, refer to your supported control panel documentation.

4 B812 Wireless SDI2 bus interface

This device connects RADION wireless peripherals to supported Bosch control panels using the SDI2 bus connection. A compatible control panel powers the receiver through the wiring connection.

Features include:

- Easy addressing via a rotary switch
- Cover and wall tamper protection
- RFID and configuration data are contained in persistent memory
- External LED
- Detection and reporting radio frequency interference
- Supports supervision of wireless points (504), keyfobs (1000), and repeaters (8)

4.1 Installation

Use the anchors and screws to install the receiver in locations accessible for future maintenance. Install the receiver onto a wall.

For best performance, place the receiver in a central location among the transmitters. For optimal communication results in situations where there is a long distance between the transmitting device and the system receiver, it might be necessary to install repeaters.



Notice!

Install the receiver in a location away from metal objects. Metal objects (duct work, wire mesh screens, boxes) reduce RF range.

4.1.1 Configuration

Configuring the address switch

This switch determines the receiver's numeric address value which the receiver will use to report receiver status information to the control panel. Set the address to the receiver prior to installation. Address 1 through 4 are valid address settings for the receiver. Use a slotted screwdriver to set the address switch.

Address settings

The receiver switches provide a single-digit setting for the receiver's address. Addresses 0 and 5 are invalid and will cause the receiver to enter into an SDI2 communication error state. This causes the receiver to be unrecognized by the control panel. The receiver uses Address 9 to reset itself when the keyfob becomes inoperable. Refer to the Notice below and procedure regarding the synchronization of the keyfob with the receiver.

Refer to your control panel documentation for information on the valid addresses for that control panel. The figure below shows the address switch setting for address 1.

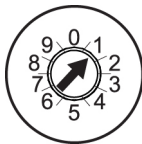

Figure 4.1: Address switch set to 1



Notice!

Inoperable RADION keyfob

If the RADION keyfob no longer operates as originally programmed, try resetting the receiver. RF IDs remain active if previously enrolled, and will not have to be re-enrolled when resetting the receiver.

Failure conditions

The following conditions describe the state of the keyfob when it no longer arms/disarms the security system:

- The keyfob is correctly programmed in the control panel, and
- The receiver LED flashes when the keyfob is activated, but
- The expected action (arm/disarm) does not occur at the control panel.

Synchronizing the keyfob with the receiver

Perform the following steps to reset the receiver and restore arming/disarming functionality for the keyfob.

Resetting the receiver:

1. Power off the receiver (or remove the receiver from its base).
2. Set the receiver address switch to 9.
3. Power on the receiver (or re-attach the receiver to its base).
4. LED indicates the firmware version. The LED turns on steady for a short time to reset the receiver, and then turns off. Replace the receiver if the LED continues to flash.
5. Power off the receiver (or remove the receiver from its base).
6. Set the receiver address switch back to the original address setting.
7. Power on the receiver (or re-attach the receiver to its base).
8. Your system is ready for normal operation.

4.1.2**Base installation**

Some consideration and planning are required when locating a position to install onto the desired surface. The base must be installed to provide plenty of accessible space to insert a flat-headed screwdriver, and remove the receiver cover for maintenance and troubleshooting.

You will need approximately 254 mm (10 in) of clearance on one side of the base to provide easy access to the opening mechanism, and approximately 15 mm (0.6 in) of clearance on the opposite side to compensate for the physical dimensions of the device cover. This should allow for adequate space in which the device cover can be opened, and the cover removed.

Other mounting considerations include;

- Minimum clearance above the location to compensate for the vertical sliding movement to attach or remove the device from the base is: >30 mm (1.2 in).
- Minimum clearance below the location where the base is mounted: >23 mm (0.9 in).

4.1.3**Wiring considerations****Notice!**

Do not install long cable runs next to high-current power feeds. Keep cable lengths as short as possible to minimize noise pickup.

Ensure that the wiring used meets the following specifications:

- Four-conductor unshielded 0.65 mm (22 AWG) to 2.0 mm (18 AWG) maximum.
- Wire length must not exceed 304.8 m (1000 ft) from the control panel

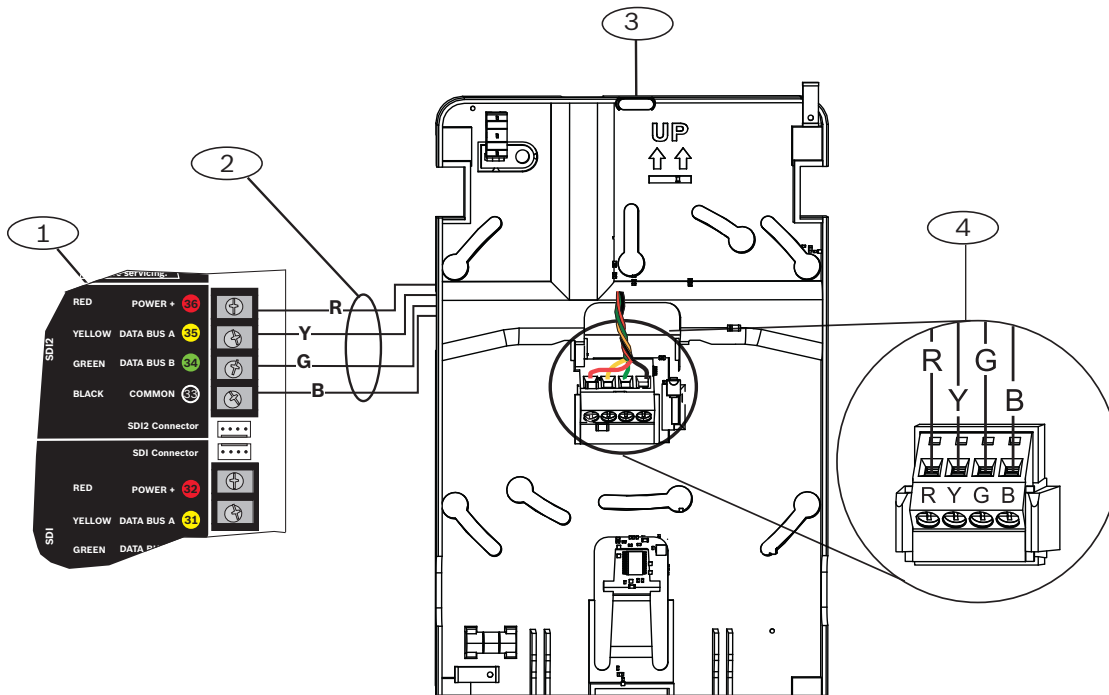

Figure 4.2: Wiring the receiver to an SDI2 compatible control panel

Callout - Description
1 - SDI2 compatible control panel
2 - Terminal wiring
3 - RADION receiver SD mounting base
4 - Module terminal block

4.1.4

Programming wireless points in the control panel

Configure the RADION points to establish communication between the RADION system and the control panel. This can be accomplished by using one of two methods:

- Using Remote Programming Software (RPS) on a supported laptop computer, or
- Compatible keypad devices to enable your points

A “point” can be a detection device, or a group of devices connected to your security system.

The first step to enable communication is to verify that the RADION transmitter is programmed into the control panel. This is achieved by configuring a point source index as wireless.

RFID programming from a supported keypad is achieved by:

- Through the point source/RFID menu options, or
- Enroll point RFID for wireless points - which uses the “Auto-Learn” methodology.

The preferred method of entering in the RFID number would be to enter it in manually through the keypad - point source/RFID, or RPS. Doing so gives you greater control and security, while reducing the risk of incomplete RFID programming.

The workflow listed below is a generic representation of the programming/enablement process. Refer to the *Points Menu Parameters* section inside the *Keypad Installer Menu* chapter of the compatible *Bosch control panel Installation and System Reference Guides*, or *Points - Point Assignments in RPS Help File* for more information.

Point source/RFID programming

A point's source gives a description as to the physical location of the point for installation and service personnel:

1. Using either RPS, or a supported keypad, access the Program Menu, and select the **Points** menu option.
2. Select the **Source** menu.
3. Select the point source of the device you are programming.
4. Change the point source to the "wireless."
5. Save changes.
6. Select the **RFID** menu to edit the RFID of each RADION device.
7. Enter in the unique RFID as it appears on the RFID sticker in the illustration below. ID's beginning with a zero may not display in the keypad UI, or RPS
8. Save changes and exit the menu.

The control panel is enabled to receive wireless communication information from the RADION transmitter.

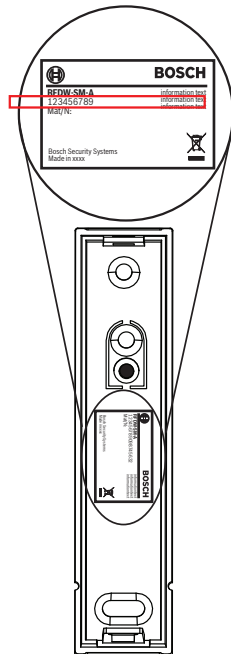

Figure 4.3: RFID sticker example

Point indexes

Point indexes determine how points operate/respond to circumstances within a system:

1. Using either RPS, or a supported keypad, access the **Program Menu**, and select the **Points** menu.
2. Select the point source of the device you are programming and select the wireless device type. Ensure that it matches that of the physical device you are enrolling.
3. Assign the attributes of the point index (how the device will respond to various circumstances).
4. Save changes and exit the menu.

Signal strength test (for repeaters)

1. From the keypad, access the **Wireless Menu**, and select **Diagnostics**.
2. Select **RF Repeaters**.
3. Select **Signal** and choose the repeater. Various sub-categories display including:
 - Signal Strength
 - Level

- Margin
4. Exit the menu.

4.1.5 Enroll point RF ID for wireless points (Auto-learn mode)

A second option exists whereby new devices are discovered on the system. This option is referred to as the “Auto Learn Mode” option. Auto Learn Mode is the process through which the control panel identifies and enrolls new device RF ID’s that appear within the system. This is achieved by the following:

- Keyfobs - when the keyfob buttons are pressed, then released.
- Motion detectors - when the battery is inserted, or if coverage pattern is disturbed by someone walking through the coverage pattern field.



Notice!

The Auto Learn mode option is not recommended as the preferred method of entering in the RF ID’s due to the potential of the RADION system picking up the first available RF ID it detects. For optimal results, manually enter in the RF ID’s through the supported keypad, or via RPS.

Enrolling a wireless point RF ID

Using a supported keypad, enroll the RF ID through the Wireless menu option. Use the **Wireless** menu to add, replace, remove, and diagnose points and repeaters.

Perform the following to enroll in the RF ID:

1. From the keypad, access the **Wireless Menu**, and select the **Points** menu option. If adding a repeater, select the **Repeater** menu option.
2. Select the option for enrolling a point RFID.
3. When asked, select the point source you are enrolling).
4. Initiate activity for the desired device (walk through the coverage pattern if enrolling a motion detector, or press the button on the keyfob if enrolling a keyfob, open the door or window if enrolling a contact). By doing so, the control panel recognizes the first RFID it comes in contact with.
5. When the keypad or RPS shows *Point Enrolled*, exit out of the application.
6. Verify the RFID displayed on the keypad matches the RFID sticker that appears on the activated device.

4.1.6 Walk test (for motion detectors)

Use the following pattern testing procedure to test the detector range and functionality.



Notice!

Also see *Control Panels (D9412GV4/D7412GV4) SIA CP-01 Quick Reference Guide P/N: F.01U.265.466*, and/or *(B6512/B5512/B4512) SIA CP-01 Quick Reference Guide P/N: F.01U.265.464*.

Motion walk test

Remove and replace cover to activate a 90-sec Walk Test Mode. During this Test Mode, any activity in the sensor’s coverage pattern will cause a transmitted alarm and LED activation. Each alarm will also extend the Test Mode for an additional 90-sec. Walk Testing should be done across the coverage pattern. The edge of the coverage pattern is determined by the first flash of the LED. This may change slightly depending upon the sensitivity setting. Walk Test the unit from both directions to determine the pattern boundaries. Although generally not required, if masking is desired, the lens diagram shows the appropriate areas to be masked. Use an opaque material (such as, electrical tape) to mask the desired areas.

Final test

While the detector is in the Walk Test Mode, turn on all heating and air conditioning sources which would normally be active during the protection period. Stand away from the sensor and outside the coverage pattern and watch for alarms. After setup and tests are completed, and there has been no activity in the sensor's coverage pattern for approximately 90-sec, the LED flashes to indicate that the Walk Test mode is ending.

Maintenance

At least once a year, a walk test should be performed to verify the range and coverage for proper operation.

Magnet walk test

Perform a magnet test to ensure proper functionality of the door and window contacts. Magnet testing can be performed by opening or closing the door/window in which the magnet is installed. In this test, you are verifying the distances of which the magnet engages and disengages the transmitter.

4.1.7**Signal level and margin**

The signal level and margin (ambient signal) of the RADION system is dependent on the receiver location and transmitters communicating with it. Installing the receiver in an environment that has a lot of radio transmitter communication or other exterior disturbances, may reduce the receiver signal strength and margin signal of the receiver.

Signal Level is a measure of how loud a RADION receiver is hearing a message from a RADION transmitter; this value is displayed as a percentage with a range of 0% - 99%.

Signal Margin is a measure of how well a RADION receiver is hearing a message from a RADION transmitter given the current ambient noise levels, or 'white noise' at the receiver. This value is displayed as a percentage with a range of 0% - 99%.

The concept of signal margin can be related to two people conversing in a room; when the room is quiet they hear each other clearly and the "signal margin" would be very high. In a noisy room they would not be able to hear each other as clearly and the "signal margin" would be much lower. When the signal margin is low enough conversation is no longer possible.

The RADION receiver monitors the signal level of every system transmitter and report an interference trouble (sometimes called Jamming) if the signal margin of a transmitter is reduced to the point where communications might be lost.

To ensure reliable system communications, the signal level and margin of every transmitter, including repeaters, should be tested and verified to be reporting "good" at the time of installation and in the unlikely event of an interference trouble report.

Signal strength test (for Points and Receiver)

Use the following procedure to test the frequency strength and range of the RADION system.

1. From the keypad, access the **Wireless Menu**, and select **Diagnostics**.
2. Select **RF Points**.
3. Select **Signal** menu and choose the desired option. Various sub-categories display including:
 - Signal strength
 - Level
 - Margin
4. Exit the menu.

Signal strength test (for Repeaters)

1. From the keypad, access **Wireless Menu**, and select **Diagnostics**.
2. Select **RF Repeaters**.
3. Select the **Signal** menu and choose the repeater. Various sub-categories display including:
 - Signal strength

- Level
 - Margin
4. Exit the menu.

**Notice!**

For UL installations, the signal shall be checked to display “good.”

4.1.8 Complete the installation

Depending on the results of testing the RADION system from a system-wide approach (walk test, signal strength and margin tests), make the appropriate modifications/adjustments to complete the install process.

4.1.9 B812 system test

Overall system test

It is recommended by UL to test the entire system at least once every year, including this receiver by an installer to ensure proper functionality of the RADION system.

4.2 External LED states

The receiver utilizes the External LED to show various states of the receiver. These states fall into the following three categories:

- Normal State
- Communication Error State
- Trouble State
- Maintenance state
- Off state

Normal state:

The receiver enters a normal state when it has passed all power self-tests and has established a communication link with the control panel . The receiver remains in this state as long as the communication link is present, and no other issues are present that would prevent the receiver from operating in a normal condition.

LED condition	State description
On (Normal)	Indicates the receiver is functioning normally.
Continuous slow flash: 1 sec On, 1 sec Off	Indicates the receiver is being programmed with the zone and transmitter ID's from the compatible control panel.
Turns Off momentarily	Indicates the receiver obtained a valid transmission from a RADION transmitter.
Flash 3 times	Indicates the receiver has obtained a new device ID while in “Learn Mode.”

Communication error state:

The receiver enters a communication error state when, during power up, it does not establish a link with the control panel, or has been in an idle state for more than 30 sec without communication. Another cause for a communication error state is an invalid address switch setting (0, or 9).

LED condition	State description
3-pulse flash: A 3-pulse signal, followed by a short delay at the end of the 3 rd pulse (Communication error)	<p>Indicates the receiver has experienced a communication failure. This error could be a result of either:</p> <ul style="list-style-type: none"> – A communication failure between the control panel and receiver, or – An invalid address switch setting

Trouble state:

The receiver enters a trouble state when an internal self-test detects a failure. Another cause for the receiver entering into a trouble state would be if the receiver detects radio frequency interference failure.

LED condition	State description
Continuous fast flash: A continuous pulse between On and Off states (Trouble state)	<ul style="list-style-type: none"> – Indicates the receiver is in a trouble state, experiencing a radio frequency interference failure – A communication failure with internal hardware components within the receiver

Maintenance state

The receiver enters a maintenance state when the address switch settings are set between switch 5 – switch 8.

LED condition	State description
Continuous Flash: A continuous pattern of short off time, followed by long on time.	Indicates the receiver is in Maintenance Mode.

Off state

Indicates there is a power failure to the receiver. Check the wire connections for proper wiring.

4.2.1**LEDs**

The receiver utilizes an external LED indicator to status the operation of the receiver. Refer to the table below for LED descriptions.

LED condition	Pattern description
On (Normal)	Indicates the receiver is functioning normally.
Off	Indicates there is a power failure to the receiver, or that the receiver is not wired correctly.

LED condition	Pattern description
Continuous Flash: 1 sec On, 1 sec Off	Indicates the receiver is being programmed with the zone and transmitter ID's from the compatible control panel.
Turns Off momentarily	Indicates the receiver obtained a valid transmission from a RADION transmitter.
Continuous Flash: A 3-pulse signal, followed by a short delay at the end of the 3 rd pulse (Communication error)	Indicates the receiver has experienced a communication error and/or a self-test failure. This error could be a result of either: <ul style="list-style-type: none"> – A communication failure between the control panel and receiver, or – An invalid address switch setting.
Continuous Flash: A continuous pulse between On and Off states (Trouble state)	<ul style="list-style-type: none"> – Indicates the receiver is in a trouble state, experiencing a radio frequency interference failure. – A communication failure with internal hardware components within the receiver
Flash 3 times:	Indicates the receiver has obtained a new radio frequency ID while in "Learn Mode".

4.3

Check-in intervals, power level, and regions for RADION devices

CTN	Check-in (minutes)	Check-in Msg TX power	UL Listed	Region
RFRP-A			x	North and South America
RFUN-A	65	3 dB lower than Alarm	x	North and South America
RFDW-SM-A	65	3 dB lower than Alarm	x	North and South America
RFDW-RM-A	65	3 dB lower than Alarm	x	North and South America
RFGB-A	65	3 dB lower than Alarm		North and South America
RFBT-A	65	3 dB lower than Alarm	x	North and South America
RFPR-12-A	65	3 dB lower than Alarm	x	North and South America
RFPR-C12-A	65	3 dB lower than Alarm	x	North and South America
RFDL-11-A	65	3 dB lower than Alarm	x	North and South America
RFPB-SB-A	65	3 dB lower than Alarm	x	North and South America
RFPB-TB-A	65	3 dB lower than Alarm	x	North and South America
RFKF-TBS-A	65	3 dB lower than Alarm	x	North and South America
RFKF-FBS-A	65	3 dB lower than Alarm	x	North and South America
RFKF-TB-A	65	3 dB lower than Alarm	x	North and South America
RFKF-FB-A	65	3 dB lower than Alarm	x	North and South America
RFSM-A /RFSM	65	3 dB lower than Alarm	x	North and South America

CTN	Check-in (minutes)	Check-in Msg TX power	UL Listed	Region
RFSM2-A	65	Same as Alarm	x	Global except for EU and China
RFCO-A	65	Same as Alarm	x	Global except for EU and China
RFHT-A	65	Same as Alarm	x	Global except for EU and China
RFPB-FP-A	13	Same as Alarm	x	Global except for EU and China
RFRP2	13	Same as Alarm	x	Global except for EU and China
RFUN	13	Same as Alarm	x	Global except for EU and China
RFDW-SM	13	Same as Alarm	x	Global except for EU and China
RFDW-RM	13	Same as Alarm	x	Global except for EU and China
RFGB	13	Same as Alarm		Global except for EU and China
RFBT	13	Same as Alarm	x	Global except for EU and China
RFPR-12	13	Same as Alarm	x	Global except for EU and China
RFPR-C12	13	Same as Alarm	x	Global except for EU and China
RFDL-11	13	Same as Alarm	x	Global except for EU and China
RFPB-SB	65	Same as Alarm	x	Global except for EU and China
RFPB-TB	65	Same as Alarm	x	Global except for EU and China
RFKF-TBS	65	3 dB lower than Alarm	x	Global except for EU and China
RFKF-FBS	65	3 dB lower than Alarm	x	Global except for EU and China
RFUN-CHI	13	Same as Alarm		China
RFDW-SM-CHI	13	Same as Alarm		China
RFPR-12-CHI	13	Same as Alarm		China
RFDL-11-CHI	13	Same as Alarm		China

CTN	Check-in (minutes)	Check-in Msg TX power	UL Listed	Region
RFPB-SB-CHI	65	Same as Alarm		China
RFKF-TBS-CHI	65	3 dB lower than Alarm		China
RFKF-FBS-CHI	65	3 dB lower than Alarm		China
RFRP2-CHI	13	Same as Alarm		China

Table 4.1: Check-in differences

4.4

Specifications

Housing dimensions (H x L x D)	209.60 mm x 139.70 mm x 31.80 mm (8.25 in x 5.50 in x 1.25 in)
Power/voltage	10 -14 VDC, 12 VDC nominal
Maximum current draw	40 mA
Device testing	To ensure proper functionality, the device must be tested at least once every year by an installer.
Operating environment	-4 °F - 131 °F -20 °C - 55 °C
Relative humidity	Up to 93% non-condensing
Frequency	433.42 MHz
IP rating	IP41
Wiring distance	Maximum distance of 304.8 m (1000 ft) from the control panel
Wiring gauge	0.65 mm (22 AWG) to 2.0 mm (18 AWG) maximum
Wall and cover tamper switch	Transmits a tamper signal when someone removes the device from its base or pulls it away from the wall.

Table 4.2: Specifications

4.4.1

Battery requirements

Use sealed lithium or alkaline batteries for supported RADION wireless system peripherals. Replace the batteries annually to ensure optimal performance.



Notice!

Dispose of used batteries according to manufacturer's instructions.

**Warning!**

The batteries used in the RADION transmitters might present a risk of fire or chemical burn if mistreated. Do not recharge, disassemble, heat above 100°C (212°F), or incinerate. Replace battery with battery manufacturer's name or end product manufacturer's name and part number only. Use of another battery might present a risk of fire or explosion.

5 RADION repeater (RFRP/RFRP2)

The RADION repeater is a wireless repeater device that re-transmits messages received from system detectors, for the purpose of improving the overall communication reliability of the wireless system. This is achieved by providing a secondary communication path for system detectors. Repeaters might be used to extend the range of a detector that must be installed beyond its maximum communication range.

An LED on the front provides device status.

Features include:

- LED Display
- Cover and Wall Tamper protection

RADION receiver compatibility

The RADION wireless security system supports the following RADION repeater models:

- RFRP/RFRP-A
- RFRP2



Notice!

Use a supported transformer as defined in the table 4.1.3 (Specifications, page 25) for the repeater. Do not connect power supply to a receptacle controlled by a switch.



Notice!

When used in a life safety application (such as in a fire warning system) at least two repeaters must be used to provide redundant communication paths. Perform the Redundant Verification Process.

5.1 RFRP2

RADION repeater receives transmissions from RADION transmitters and re-transmits them to improve transmitted message reliability and range for compatible transmitters and its assigned compatible receiver. RADION repeaters are ideal for large facilities, and multi-level buildings, retail stores, college campus, and malls.

5.1.1 Installation considerations

Use the provided anchors and screws to mount the repeater in locations accessible for future maintenance. Mount the repeater onto a wall.



Notice!

Mount the repeater in a location away from metal objects. Metal objects (duct work, wire mesh screens, boxes) reduce RF range

5.1.2 Redundant communication verification process



Notice!

If this is a new install, keep the plastic battery tab in the current position, perform the verification process, and then remove the plastic tab. If the repeater has already been installed, and the plastic tab removed, re-insert the plastic tab into the battery terminal before performing the verification process.

1. Build a network of repeaters.
2. Remove DC and battery power from one repeater.
3. Start all other repeaters by removing and reinserting the repeater back onto the mounting plate.
4. Make sure all repeaters have “good” signal strength as displayed in RPS or from the control panel keypad.
5. Re-apply the DC and battery power to the current repeater.
6. Repeat steps 2-5 until all repeaters in your environment have gone through the verification process and a redundant communication path is confirmed.
7. Make sure all other devices operate and report correctly, and have good signal strength.

5.1.3 Specifications



Notice!

UL system compliance

For UL system compliance the RFRP2 shall be connected to a UL Listed Residential Fire/UL Residential Burg/ Commercial Burglar Alarm power supply with a class 2 power limited output with a voltage range of 10-14VDC , (nominal)1 Amp @12VDC Max.

Dimensions	139.70 mm x 209.60 mm x 33.20 mm (5.50 in x 8.25 in x 1.31 in)
Compatible power supply	Compatible plug-in transformers for use with the RFRP2 repeater: – WR9QE1000A00N6WG3150 - 12V, 1A power supply with NAM blade. (S/N: F.01U.398.526) For installations other than the U.S., transformers must meet the country-specific requirements.
Compatible blade kit	– Q-KIT-INTL-6-WH-RB - International blades for 12V, 1A. (S/N: F.01U.398.527)
Power/voltage	12 VDC, 1 A
Standby battery	This component is internal and not user replaceable. (3.6 VDC, 3180 mA)
Typical current draw	45 mA
Temperature (operating)	Charging range: +10°C to +45°C (+50°F to +113°F) Functional range: 0°C to +49°C (+32°F to +120°F)
Relative humidity	0% to 93% (non-condensing)
Device testing	To ensure proper functionality, the device must be tested at least once every year by an installer.
Wall and cover tamper switch	Transmits a tamper signal when someone removes the device from its base or pulls it away from the wall.
Frequency	433.42 MHz

5.1.4 LEDs

Refer to the external LED indicator to get operational status.

LED Condition	Pattern Description
On (Normal)	– Indicates the repeater is functioning normally.
Off	– Indicates there is a power failure to the repeater, or that the receiver is not wired correctly.
Continuous Flash: 1 sec rate for 5 sec	– Indicates the repeater is being powered up, and conducting manufacturing test initializations.
Continuous Flash: A 3-pulse signal, followed by a short delay after the 3 rd pulse	– Indicates the repeater has experienced a low battery condition.
Continuous Flash: A 2 flash pattern continuous pulse between On and Off states with a short delay after the 2 nd pulse	– Indicates an AC power failure is detected. – A communication failure within internal hardware components inside the receiver

Table 5.1: LED descriptions

6 RADION glassbreak (RFGB)

The RADION glassbreak is a wireless transmitter used for detecting breaking glass. Throughout this document, the term “glassbreak” refers to glass break.

Features include:

- Monitored battery status

Dimension	101.42 mm x 112.90 mm x 35.00 mm (3.99 in x 4.44 in x 1.38 in)		
Power/Voltage	Battery/CR123A, 3 VDC () Power source type: C Low battery level: 2.15V		
Battery replacement	Duracell PC1500, Duracell DL123A, Lithium, Panasonic CR123A Lithium, or Sanyo CR123A Lithium. Check your battery yearly to ensure proper functionality.		
Battery life	Up to 5 years		
Device testing	To ensure proper functionality, the device must be tested at least once every year.		
Acoustic Capabilities	Glass types and thickness	Type	Thickness
		Plate	2.4 mm to 6.4 mm (3/32 in to 1/4 in)
		Tempered	3.2 mm to 6.4 mm (1/8 in to 1/4 in)
		Laminated	3.2 mm to 6.4 mm (1/8 in to 1/4 in)
		Wired	6.4 mm (1/4 in)
	Minimum pane size for all types of glass	1.2 m (4 ft)	
Microphone	Omni-directional 360° electret		
Operating Temperature	Functional range: -10°C to +49°C (+14°F to +120°F) UL only: 0°C to +49°C (+32°F to +120°F)		
Relative Humidity	0% to 93% (non-condensing)		
Wall and Cover Tamper Switch	Transmits a tamper signal when someone removes the device from its base or pulls it away from the wall.		
Frequency	433.42 MHz		

Table 6.1: Specifications

6.1 Installation considerations

For the best detector performance, select a mounting location that is:

- Mounted on the ceiling within a maximum range of 6 m (20 ft)
- For armor-coated glass installations, mount the sensor no more than 3.65 m (12 ft) from the glass

- Mount the detector in the direct line of sight of the glass to be protected
- On an opposite, or adjoining wall, within a range of 6 m (20 ft) for plate, tempered, laminated, and wired glass
- In a suitable environment: temperature between -18 and 50°C (0 and 120°F); and humidity between 10 and 90% non-condensing

Avoid mounting the detector in:

- Glass airlocks and glass vestibule areas
- Humid rooms
- Small utility rooms
- Rooms with noisy equipment (white noise) such as air compressors, bells, and power tools
- Rooms smaller than 3 m x 3 m (10 ft x 10 ft)
- Rooms with lined, insulating, or sound suppressing drapes
- A corner of a room

Avoid locations that expose the detector to possible false-alarm sources such as:

- Glass airlocks and vestibule areas;
- Kitchens;
- Corner mounting;
- Residential car garages;
- Stairwells
- Bathrooms; and
- Small acoustically live rooms



Notice!

Glassbreak detectors are intended only as a component of a perimeter protection system. Use glassbreak detectors in conjunction with motion detectors.

6.2

Testing

Test the detector at least once yearly. Use the Sentrol 5709C hand-held tester to enter the sensor into test mode and to test the alarm.

Test the sensor alarm

To test the sensor functionality, enter the detector into test mode. In normal mode, the sensor does not generate an alarm on sound signals from the tester unless the tester is held next to the sensor.

Each time the sensor alarms, it also goes into test mode for one minute.

Initiating test mode with the Sentrol 5709C hand-held tester:

1. Set the tester for tempered or laminated glass, unless the protected glass is plate glass.
2. Hold the tester on top of the detector.
3. Activate the tester. The detector alarms and goes into test mode for one minute. During test mode, the LED blinks continuously. To extend test time, activate the tester within the range of the sensor at least once each minute.

Performing the alarm test with Sentrol 5709C hand-held tester:

1. Hold the tester near the surface of the glass to be protected and aim the speaker at the sensor. Be sure the tester is at the point on the glass farthest from the detector.



Notice!

If blinds or drapes are present, test the area by holding the hand-held tester behind the closed blinds or drapes.

2. Press the test button on the tester. The LED on the detector stays on for 4 seconds to indicate the glass is within detection range of the sensor. If the LED does not stay in a solid state momentarily, but continues to blink, adjust the positioning of the detector so that it is closer to the window, and re-test. Check the battery strength of the hand-held testing device before the test.

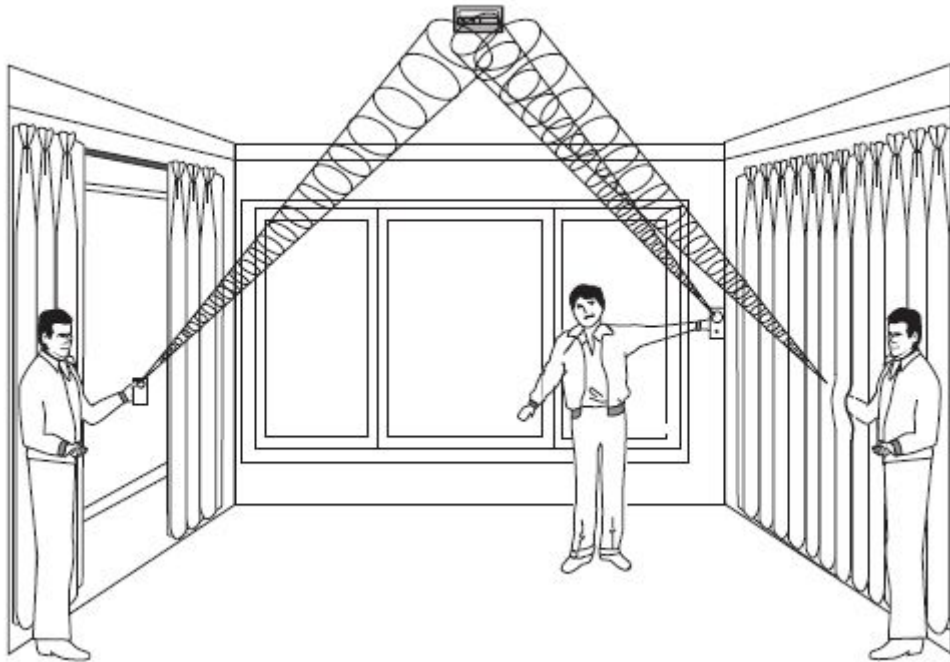

Figure 6.1: Testing behind curtains

The detector switches from test mode to normal mode after at least 1 minute of silence from the hand-held tester.



Notice!

When the detector is in normal mode, the LED is off unless a loud sound is detected.

Room acoustics can artificially extend the range of a glassbreak sensor. The specified sensor range is for worst-case conditions. While the sensor likely functions at a greater range, it might not detect a low volume breaking sound, or room acoustics might change at a later point in time. Do not exceed the rated range of the sensor, regardless of what the tester shows.

Test the sensor operability

When the detector is in normal mode, the LED is off unless a loud sound is detected. Therefore, to ensure the glassbreak has power and that the microphone is functional, perform a simple hand clap test.

To perform a hand clap test, simply clap your hand loudly under the sensor. Verify the LED blinks twice.

6.3

Low battery

When a low battery state is detected, the detector measures the battery, and sends a report to the receiver/control panel.

6.4 **Wall Tamper Tab**

Use the wall tamper tab to activate an alarm when the glass break has been removed from the wall.

6.5 **Maintenance**

Clean the cover with a damp (water) cloth as needed to keep it free of dust and dirt. Always test the sensor after cleaning it.

7 RADION TriTech (RFDL-11)

The RADION TriTech is a motion detector which uses artificial intelligence to detect motion and provide immunity to false alarms. An integral RF transmitter reports low battery and tamper status, and sends a supervisory signal to the control panel. Features include:

- 11m x 11m (35 ft by 35 ft) coverage
- Flexible mounting height
- Compatible with Bosch RADION wireless systems
- Draft and Insect immune
- Cover activated tamper indication. Optional wall-activated tamper is included

Dimension	138.00 mm x 72.00 mm x 64.00 mm (5.43 in x 2.83 in x 2.52 in)
Relative humidity	0% to 93%, (non-condensing)
Temperature (operating)	Functional range: -10°C to +49°C (+14°F to +120°F) UL only: 0°C to +49°C (+32°F to +120°F)
Internal coverage directionality	Vertical: -4° to -10°
Sensitivity selection	Field selectable for standard or intermediate sensitivity
Power/voltage	Four AA Alkaline batteries, 1.5 VDC (—). 1.5 VDC x 4 = 6 VDC total. Power source type: C Low battery level: 3.6V
Battery replacement	Duracell MN1500, Panasonic AM-3PIX. Check your battery yearly to ensure proper functionality.
Battery life	Up to 5 years
Device testing	To ensure proper functionality, the device must be tested at least once every year by an installer.
Wall and cover tamper switch	Transmits a tamper signal when someone removes the device from its base or pulls it away from the wall.
Frequency	433.42 MHz

Table 7.5: Specifications

7.1 Mounting height and range adjustment

Loosen the vertical adjustment screw. Adjust the board to the desired angle. Choose mounting height and desired range, and set the vertical angle. Reference the table below for proper height and adjustment values.

Mounting height	Range	
	6.1 m (20 ft)	10.7 m (35 ft)
2 m (6.5 ft)	-7°	-5°

2.1 m (7.0 ft)	-9°	-6°
2.4 m (8.0 ft)	-10°	-7°

Table 7.2: Mounting height

**Notice!**

The mounting height must be 2 m (6.5 ft) and the vertical angle must be set at -5° for installations containing pets.

The vertical adjusting screw must be securely tightened after setting the angle.

7.2 Sensitivity settings

Standard sensitivity

Use this setting when pets are present in the monitored area. Standard sensitivity provides excellent detection performance and is the least sensitive to false alarms.

Intermediate sensitivity

Only use this setting in non-pet installations with minimal environmental disturbances. Intermediate sensitivity provides the highest level of detection performance.

7.3 Walk testing

**Notice!**

To maximize battery life, the LED elements do not activate unless the unit is in the Walk Test mode.

Perform a walk test to determine the boundaries of the coverage area. Perform this test at the time of installation and monthly thereafter. To ensure continual daily operation, instruct the end user to walk through the far end of the coverage pattern. This ensures an alarm output prior to arming the system. Start Walk Test mode from the detector. Insert a slotted screwdriver to open the detector cover and then close the detector cover to start a 90-sec Walk Test mode.

**Notice!**

In the normal operating mode, an alarm can be transmitted only after three (3) minutes have passed since the previous alarm restoral. This 3 minute lockout time reduces unnecessary RF transmissions in high traffic areas, thereby extending battery life.

During this test mode, motion detected within the detector's coverage area causes a transmitted alarm and LED activation. Each alarm will also extend the Test Mode. Watch for the green LED to indicate the edges of the Microwave pattern. Adjust as necessary.

Please reference the LED table below for LED descriptions.

LED Condition	Cause
Steady red	PIR activation (Walk Test)
Steady green	Microwave activation
Steady blue	Alarm signal

LED Condition	Cause
Flashing blue	Warm-up period after power-up
No LED upon initial power up	PIR failure. Replace unit.

Table 7.3: LED description

Walking Testing the system

1. Start at the pattern’s expected boundary and walk across the pattern moving closer to the detector. Set the adjustment as low as possible for proper catch performance.

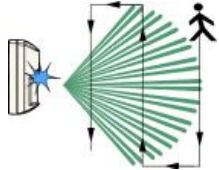

2. Adjust the Microwave Range Adjustment Potentiometer to as low a setting as possible for proper catch performance.

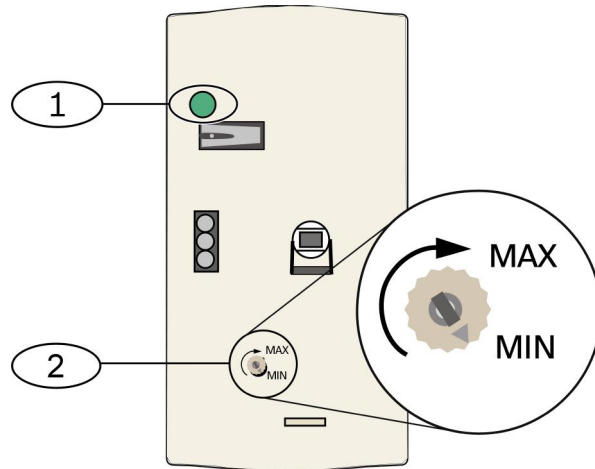

Figure 7.1: Sensitivity settings

Callout - Description
1 - Alarm LED (blue, green, or red)
2 - Microwave Range Adjustment Potentiometer

3. At each pass, observe the color on the Alarm LED (refer to the Sensitivity settings figure above).
4. Walk test from the opposite direction to determine the coverage pattern boundaries from both sides.
5. When walk test is completed, the detector returns to normal operation after 90 sec of inactivity.

8 RADION PIR (RFPR-12)

The RADION PIR is a high performance PIR motion detector that uses advanced signal processing. An integrated wireless transmitter sends a battery report with each transmission, and transmits a supervisory signal to the control panel. Features include:

- 12 m x 12 m (40 ft x 40 ft) coverage
- Flexible Mounting Height

Dimensions	111.00 mm x 60.00 mm x 43.00 mm (4.40 in x 2.40 in x 1.70 in)
Relative humidity	0% to 93%, non-condensing
Temperature (operating)	Functional range: -10°C to +49°C (+14°F to +120°F) UL only: 0°C to +49°C (+32°F to +120°F)
Power/voltage	One CR123A Lithium battery, 3 VDC (≡≡≡) Power source type: C Low battery level: 2,15V
Battery replacement	Duracell DL123A , Panasonic CR123A, or Sanyo CR123A. Check your battery yearly to ensure proper functionality.
Battery life	Up to 5 years
Device testing	To ensure proper functionality, the device must be tested at least once every year by an installer.
Wall and cover tamper switch	Transmits a tamper signal when someone removes the device from its base or pulls it away from the wall.
Frequency	433.42 MHz

Table 8.8: Specifications

8.1 Walk testing

Perform a walk test to determine the boundaries of the coverage area.

Insert a slotted screwdriver into the designated hole to open the cover and then close the detector cover to start a 90-sec Walk Test mode.

During this test mode, motion detected within the detector's coverage area causes a transmitted alarm and LED activation. Each alarm will also extend the Test Mode. Adjust as necessary.



Notice!

Excessive use of the Walk Test Mode may reduce battery life. Use only for initial setup and maintenance testing.



Notice!

In the normal operating mode, an alarm can be transmitted only after three (3) minutes have passed since the previous alarm restoral. This 3 minute lockout time reduces unnecessary RF transmissions in high traffic areas, thereby extending battery life.

Refer to the LED table below for LED descriptions.

LED condition	Cause
Steady blue	PIR activation (Walk Test)
Flashing blue	Warm-up period after power-up
Flashing blue (four-pulse sequence)	PIR failure. Replace unit.

Table 8.2: LED description

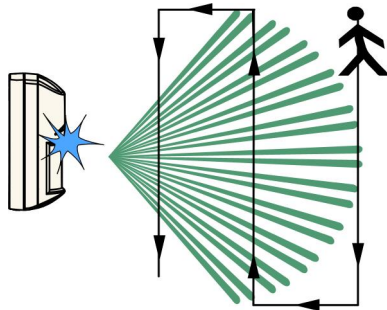

Figure 8.1: Walk test

1. Start at the pattern's expected boundary and walk across the pattern moving closer to the detector (refer to the Walk test figure above).
2. While the detector is in the Walk Test Mode, turn ON all heating and air conditioning sources which would normally be active during the protection period. Stay away from the sensor and outside the coverage pattern and watch for alarms.
3. The LED flashes at the completion of a 90-sec span of time, indicating that the Walk Test mode is ending. This occurs when there is no activity in the sensor's coverage pattern during the 90-sec interval.
4. When walk testing is completed, the detector returns to normal operation after 90 seconds of inactivity.

9 RADION PIR C (RFPR-C12)

The RADION PIR with curtain detecting capability is a high performance curtain PIR motion detector that uses advanced signal processing to provide outstanding catch performance and unsurpassed false alarm immunity. The detector contains an integrated RF transmitter. The transmitter sends a battery report with each transmission, and transmits a supervisory signal to the control panel.

Features include:

- 12 m x 1.5 m (40 ft x 5 ft) curtain coverage
- Flexible Mounting Height

Dimensions	111.00 mm x 60.00 mm x 43.00 mm (4.40 in x 2.40 in x 1.70 in)
Relative humidity	0% to 93%, non-condensing
Temperature (operating)	Functional range: -10°C to +49°C (+14°F to +120°F) UL only: 0°C to +49°C (+32°F to +120°F)
Power/voltage	One CR123A Lithium batteries, 3 VDC (≡≡≡) Power source type: C Low battery level: 2,15V
Battery replacement	Duracell DL123A, Panasonic CR123A, or Sanyo CR123A. Check your battery yearly to ensure proper functionality.
Battery life	Up to 5 years
Device testing	To ensure proper functionality, the device must be tested at least once every year by an installer.
Wall and cover tamper switch	Transmits a tamper signal when someone removes the device from its base or pulls it away from the wall.
Frequency	433.42 MHz

Table 9.1: Specifications

9.1 Walk testing

Perform a walk test to determine the boundaries of the coverage area.

Insert a slotted screwdriver into the designated hole to open the cover and then close the detector cover to start a 90-sec Walk Test mode.

During this test mode, motion detected within the detector's coverage area causes a transmitted alarm and LED activation. Each alarm will also extend the Test Mode. Adjust as necessary.



Notice!

Excessive use of the Walk Test Mode may reduce battery life. Use only for initial setup and maintenance testing.



Notice!

In the normal operating mode, an alarm can be transmitted only after three (3) minutes have passed since the previous alarm restoral. This 3 minute lockout time reduces unnecessary RF transmissions in high traffic areas, thereby extending battery life.

Refer to the LED table below for LED descriptions.

LED condition	Cause
Steady blue	PIR activation (Walk Test)
Flashing blue	Warm-up period after power-up
Flashing blue (four-pulse sequence)	PIR failure. Replace unit.

Table 9.2: LED description

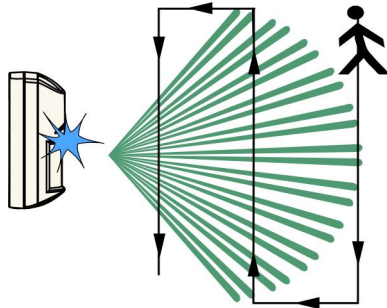

Figure 9.1: Walk test

1. Start at the pattern's expected boundary and walk across the pattern moving closer to the detector (refer to the Walk test figure above).
2. While the detector is in the Walk Test Mode, turn ON all heating and air conditioning sources which would normally be active during the protection period. Stay away from the sensor and outside the coverage pattern and watch for alarms.
3. The LED flashes at the completion of a 90-sec span of time, indicating that the Walk Test mode is ending. This occurs when there is no activity in the sensor's coverage pattern during the 90-sec interval.
4. When walk testing is completed, the detector returns to normal operation after 90 seconds of inactivity.

10 RADION smoke (RFSM)

The RADION smoke is a non-latching wireless smoke detector that sends an alarm signal to the receiver.

The following features include:

- A visual status LED
- A built-in sounder for alarm alerts
- Under normal conditions, the red LED flashes once every 8 sec while the sensor monitors the surrounding environment. When the sensor detects smoke, the LED changes from flashing to steady ON and the sounder produces a loud, continuous tone. Refer to the LED table for more information.

Replaceable optical chamber	For easy maintenance
Power/voltage	Two CR123A Lithium batteries, 3 VDC (== ==) Power source type: C Low battery level: 2.15V
Current draw	Standby: 45 uA Alarm: 70 mA
Battery replacement	Duracell DL123A, Panasonic CR123A, or Sanyo CR123A. Check your batteries yearly to ensure proper functionality.
Battery life	Minimum of 5 years or greater
Device testing	To ensure proper functionality, the device must be tested at least once every year.
Sensitivity	0.14+/- 0.04 bM/m (0.97 - 2.99%/ft obscuration - RFSM-A only)
Temperature (operating)	Functional range: -10°C to +49°C (+14°F to +120°F) UL only: 0°C to +49°C (+32°F to +120°F)
Relative humidity	0% to 93% (non-condensing)
Cover and wall tamper switch	Transmits a tamper switch signal when the detector is removed from its base, or the unit is pulled away from the wall.
Drift compensation adjustment	1.64%/m (0.5%/ft) maximum
Sounder	85 dBA at 3 m
Self-diagnostics feature	Monitors detector sensitivity and operational status.
Frequency	433.42 MHz

Table 10.1: Specifications

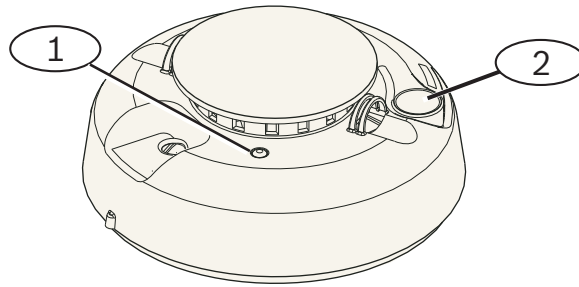

Figure 10.1: Smoke detector

1 - High intensity LED

2 - Test/Silence button

10.1 Battery replacement

Under normal conditions, the LED normally flashes every 8 sec to indicate normal operating conditions. Replace the battery when the LED stops flashing, and the detector chirps every 45 sec. Silence the low battery trouble chirps for 24 hr by pushing the **Test/Silence** button. Refer to the Smoke detector illustration for locating the **Test/Silence** button.

10.2 Smoke test

Test smoke detectors annually by using a listed aerosol smoke tester to simulate an alarm. Follow the instructions on the can.

The LED should remain ON while the detector provides a continuous tone. The detector automatically resets when smoke is no longer present. A detector that fails to activate with the smoke test might require cleaning or replacement.



Notice!

To avoid a fire department dispatch, contact central monitoring station, or put the system into Test mode before activating the detector using this method.

10.3 Sensitivity test



Notice!

The control panel recognizes Test Mode as a test. It does not send an alarm.

The detector includes a Sensitivity Level Test mode for determining the detector's sensitivity:

1. Press and hold the **Test/Silence** button for 4 sec. The LED flashes 1 to 9 times.
2. Count the number of LED flashes and use the *Smoke detector sensitivity conditions* table to determine the status of the detector's sensitivity and the recommended action.

Flashes	Action Recommended
1	Self-diagnostics failure. Return detector for service or replacement.

Flashes	Action Recommended
2 to 3	Detector is becoming insensitive. Clean detector and re-test. If error persists, replace the detector.
4 to 7	Detector is within normal sensitivity settings.
8 to 9	Detector is becoming too sensitive. Confirm that the smoke chamber is snapped down securely. Clean the sensor and re-test.

Table 10.2: Smoke detector sensitivity conditions

10.4 Test/Silence button

Refer to the RADION smoke detector illustration for location of the **Test/Silence** button.

- Testing. Press the Test/Silence button for 4 sec. The detector performs a Sounder test and a Sensitivity test.
- Silence alarm. Press to silence the sounder during an alarm. After a few minutes, the sounder and alarm resume if smoke is still present.

Remote monitoring station alarm test

Press the button for fifteen (or 20) seconds to send a fire alarm signal to the remote monitoring station.



Notice!

To avoid a fire department dispatch, contact the remote monitoring station or put the control panel into the corresponding test mode before performing this test.

10.5 LED

LED	Status
Flashing	Flashes every 8 sec under normal operation.
ON	Detects smoke, sending an alarm.
OFF	Malfunction, replace the batteries, clean the detector, or replace the optical chamber as required.

Table 10.3: LED

10.6 Clean the detector and replace the optical chamber

Clean the detector cover with a dry or damp cloth as needed to keep it free from dust and dirt. Clean the detector interior at least yearly.

Cleaning the detector:

1. Remove the detector from the mounting base.
2. Remove the batteries.
3. Slide a slotted screwdriver into the slot on the detector cap and gently push down to pry off the cap.

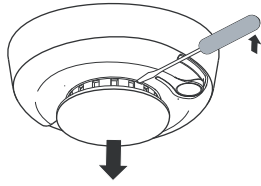

Figure 10.2: Remove the detector cap

4. Squeeze the optical chamber where indicated and pull it up and away from the detector.

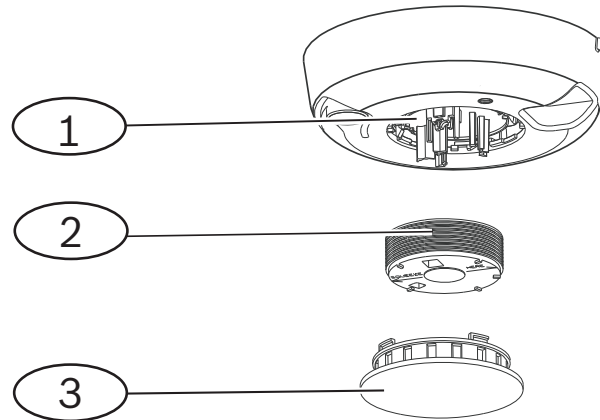

Figure 10.3: Remove the detector cap

1 - Optical base
2 - Optical chamber
3 - Detector cap

5. Use compressed air or a soft-bristled brush to remove dust and dirt from the smoke chamber base.
6. Align the optical chamber with the base and snap down into place.
7. To attach the detector cap, line the cap up with the detector, press the cap onto the detector, and turn clockwise to snap it firmly into place.
8. Observing the proper polarity, install the batteries and the battery cover. If the batteries are not installed properly, the detector will not fit onto the mounting base. Ensure that the batteries are properly installed.
9. Mount the detector onto the mounting base.
10. Test the detector's sensitivity.

11 RADION smoke (RFSM2-A)

This smoke detector includes a photoelectric sensor that senses low energy smoke particles. The detector is sensitive to all domestic fire types but is especially sensitive to smoldering fires and is ideal for bedrooms and children's rooms. The RFSM2-A smoke detector also includes a fixed and rate-of-rise heat sensor for fire detection.

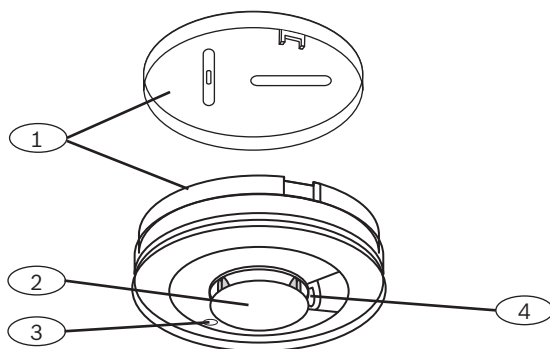

Callout - Description
1 - Mounting plate
2 - Test/Silence button
3 - LED
4 - Sounder

For more information, refer to the RADION Life Safety Installation Manual P/N: F.01U.361.555.

12

RADION contact SM (RFDW-SM)

The RADION contact SM door/window contact is a standard surface-mount wireless transmitter device used for monitoring doors and windows.

Features include:

- An internal reed switch
- A cover and wall tamper switch

Power/voltage	One AAA Lithium battery, 1.5 VDC () Power source type: C Low battery level: 0.9V
Battery replacement	Energizer L92. Check your battery yearly to ensure proper functionality.
Battery life	Up to 5 years
Device testing	To ensure proper functionality, the device must be tested at least once every year by an installer.
Dimensions (transmitter)	19.50 mm x 82.55 mm x 12.80 mm (0.76 in x 3.25 in x 0.50 in)
Dimensions (magnet)	24.5 mm x 18.5 mm x 12.5 mm (0.97 in x 0.72 in x 0.49 in)
Temperature (operating)	Functional range: -10°C to +49°C (+14°F to +120°F) UL only: 0°C to +49°C (+32°F to +120°F)
Relative humidity	0% to 93% (non-condensing)
Wall and Cover Tamper Switch	Transmits a tamper signal when someone removes the device from its base or pulls it away from the wall.
Frequency	433.42 MHz

Table 12.1: Specifications

12.1

Installation considerations

You have a variety of installation options to consider when installing the device. You must acknowledge the unique installation approach prior to installation. Some installation considerations include:

- Suitable surfaces for installation include wood, steel, and aluminum.
- The location of the magnet and transmitter in relationship to the door/window frame dimensions. Verify you have proper clearance with the latch of the window or door you are installing the device onto. Failure to do so will make it extremely difficult to access and open the device for maintenance purposes.
- In some cases, you might need an additional spacer when installing the transmitter and magnet in the corner of a recessed door or window frame to close the gap in height between the magnet and transmitter.
- For additional security, you can use an adhesive with the screws to secure the transmitters and magnets during installation.

- When installing the magnet, verify that the notches in the magnet base, line up with the notches in the transmitter base, otherwise the magnet and transmitter do not function effectively.
- When installing the magnet base, install the face of the magnet base flush to the surface edge of the installation location. This prevents damage to the magnet plastic base whenever a window or door is opened.
- Adhere to the distances prescribed in the graphical table found in the graphical *Installation and Operation Guide* when installing the magnet adjacent to the transmitter.

How to read the Graphical Magnet Distances table

Contained in the RADION contact SM *Installation Guide* is a graphical table along with the X - Y - Z coordinates graphic. Use the table in conjunction with the graphic to determine desired distances between the magnet and the transmitter based on the type of installation (wood or metal).



Notice!

The content in the *Installation Guide* table applies to EN installations.

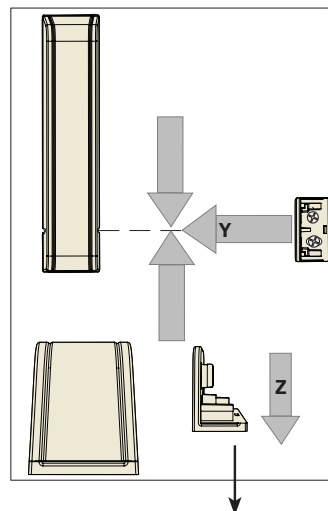
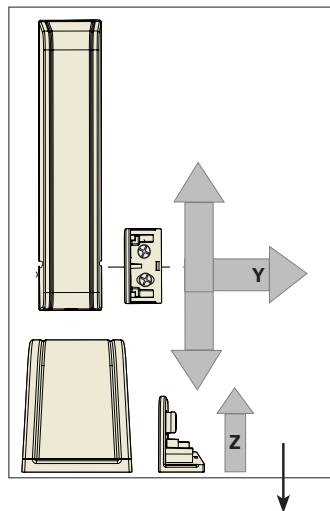

	Y	20.0 ± 4.0 mm (0.79 ± 0.16 in)
	X1	13.0 ± 3.0 mm (0.51 ± 0.12 in)
	X2	15.5 ± 4.5 mm (0.61 ± 0.18 in)
	Z	23.0 ± 5.0 mm (0.91 ± 0.13 in)
	Y	14.0 ± 7.0 mm (0.55 ± 0.28 in)
	X1	13.0 ± 5.0 mm (0.51 ± 0.13 in)
	X2	14.0 ± 6.0 mm (0.55 ± 0.24 in)
	Z	21.5 ± 1.5 mm (0.85 ± 0.06 in)

	Y	19.0 ± 4.0 mm (0.75 ± 0.16 in)
	X1	12.0 ± 3.0 mm (0.47 ± 0.12 in)
	X2	14.5 ± 4.5 mm (0.57 ± 0.18 in)
	Z	22.0 ± 5.0 mm (0.87 ± 0.13 in)
	Y	13.0 ± 7.0 mm (0.51 ± 0.28 in)
	X1	12.0 ± 5.0 mm (0.47 ± 0.13 in)
	X2	13.0 ± 6.0 mm (0.51 ± 0.24 in)
	Z	20.5 ± 1.5 mm (0.81 ± 0.06 in)

13

RADION contact RM (RFDW-RM)

The RADION contact RM is a recessed-mounted wireless transmitter device used for monitoring doors and windows. Features include:

- Self-contained transmitter with magnetic reed switch
- Tamper protection
- Recessed mounting on doors or windows

Power/voltage	One AAA Lithium battery, 1.5 VDC () Power source type: C Low battery level: 0.9V
Battery replacement	AAA Lithium Battery L92. Check your battery yearly to ensure proper functionality.
Battery life	Up to 5 years
Device testing	To ensure proper functionality, the device must be tested at least once every year by an installer.
Dimensions (transmitter)	19.00 mm x 104.80 mm (0.75 in x 4.12 in)
Dimensions (magnet)	22 mm x 28 mm x 15 mm (0.87 in x 1.10 in x 0.59 in)
Relative humidity	0% to 93%, non-condensing
Temperature (operating)	Functional range: -10°C to +49°C (+14°F to +120°F) UL only: 0°C to +49°C (+32°F to +120°F)
Frequency	433.42 MHz

Table 13.1: Specifications

13.1

Installation considerations

You have a variety of installation options to consider when installing the device. You must acknowledge the unique installation approach prior to installation. Some installation considerations include:

- The installation of this device is suitable for wood surfaces. This device is not suitable for steel surfaces.
- The transmitter housing was designed to be open with a coin. Using a screwdriver may cause damage to the plastic top.
- When reinserting the PCB (battery and antenna assembly), verify that the PCB assembly fits into the grooves of the transmitter housing.
- When reinserting the plastic top, verify that the top fits into the designed grooves of the transmitter housing.
- When installing the transmitter in an overhead location, be mindful that the PCB assembly may fall out of the transmitter housing.
- The removal of the plastic flaps is optional, depending on your installation needs.
- For added security, you can use an adhesive with the screws to secure the transmitters and magnets.



Notice!

EN requirements

For further information regarding certified installations, please refer to EN product requirements.

How to read the Graphical Magnet Distances table

Contained in the recessed door/window contact *Installation Guide* is a graphical table along with the X - Y coordinates graphic. Use the table in conjunction with the graphic to determine desired distances between the magnet and the transmitter based on the type of installation.

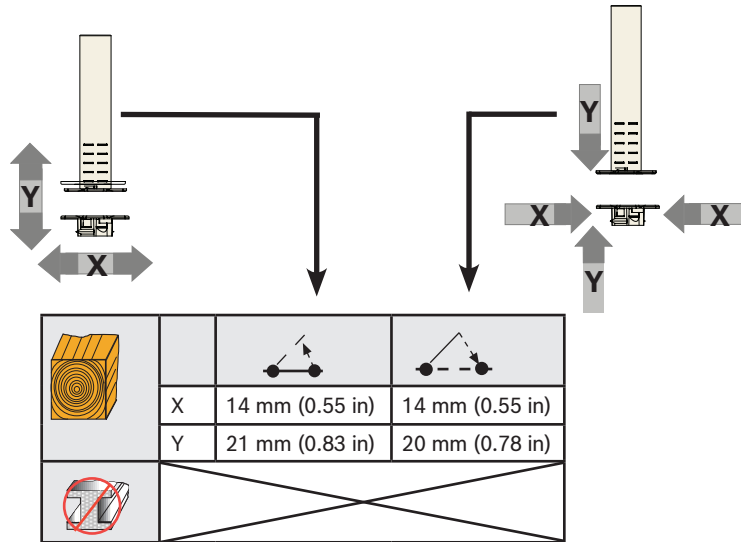

14

RADION specialty (bill trap/RFBT)

RADION specialty is a designed transmitter (bill trap) specifically used in financial or retail environments. It transmits a silent, wireless alarm signal without local notification (no LED activation) when a bill, or any other form of paper currency is removed from the transmitter - typically, the last bill in the bottom of a cash drawer.

Features include:

- Brief illumination of LED to signify armed and operational status
- Wall tamper alarm when removed from the cash drawer.

Dimensions	48.80 mm x 154.10 mm x 23.60 mm (1.92 in x 6.06 in x 0.93 in)
Power/voltage	1.5 VDC, Lithium () Power source type: C Low battery level: 0.9V
Battery replacement	AAA Lithium Battery L92. Replace your battery yearly to ensure proper functionality.
Battery life	Up to 5 years
Device testing	To ensure proper functionality, the device must be tested at least once every year.
Relative humidity	Up to 93%, non-condensing
Temperature (operating)	Functional range: -10°C to +49°C (+14°F to +120°F) UL only: 0°C to +49°C (+32°F to +120°F)
Frequency	433.42 MHz

Table 14.1: Specifications

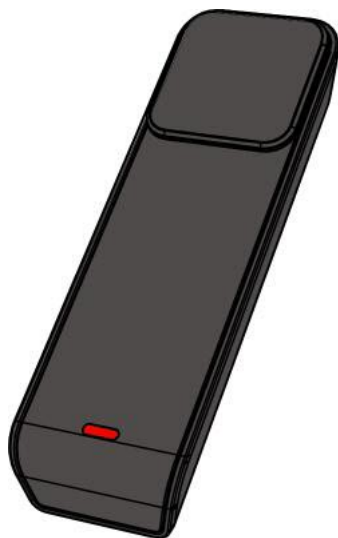

Figure 14.1: Specialty

14.1 Applications for this product

Usage of this product is to provide concealed protection against theft in a financial institution such as a bank, or in other commercial environments such as retail businesses and shops. In some cases, the cash drawer is removed from the teller or cashier station, and stored inside a bank vault at the close of each business day. In this scenario, the bank vault system is always armed, and the bill trap remains in a non-faulted condition. It is recommended to use the 3M double sided tape when inserting into the cash drawer.

In other occasions, the bill trap itself may be removed from the cash drawer at the end of a workers shift. In this situation, the bill trap unit will generate a tamper condition upon removal. In this type of application, it is important that the system must be configured such that the tamper does not generate a silent alarm. For this occasion, the hook and loop may be a more suitable mounting technique.

14.2 Installation consideration

During the installation process, use the self-adhesive Velcro strips located on the bottom of the bill trap base, to secure and stabilize the bill trap in the cash drawer. This is achieved by performing the following:

1. Separate the Velcro strips from one another.
2. Peel off the protective backing of the Velcro strips.
3. Press the two bottom sections of the Velcro onto the bottom of the cash drawer, in the desired location.
4. Line up and press down on the bill trap so that the Velcro on the bottom of the bill trap is aligned with the Velcro strips inside the cash drawer.



Warning!

It is important to check the Velcro strips on a weekly basis for wear and replace when appropriate in order to prevent potential false alarms.

15

RADION universal transmitter (RFUN)

The RADION universal is a wireless detector used for monitoring doors, windows, and other dry contact devices.

Features include:

- A cover and wall tamper switch
- Single input with magnetic contact
- Ability to connect to an external detector

Item	Specification
Dimensions (transmitter)	82.55 mm x 33.02 mm x 19.50 mm (3.25 in x 1.30 in x 0.76 in)
Dimensions (magnet)	24.50 mm x 18.50 mm x 12.50 mm (0.97 in x 0.72 in x 0.49 in)
Wire gauge	0.65 mm (22 AWG) to 1.5 mm (16 AWG)
Wiring distance	Maximum distance of 7.62 m (25 ft)
Power/voltage	Lithium battery, 3 VDC (— — —) Power source type: C Low battery level: 2.15V)
Battery replacement	One Duracell DL123A, or Panasonic CR123A, or Sanyo CR123A. Check your battery yearly to ensure proper functionality.
Battery life	Up to 5 years
Device testing	To ensure proper functionality, the device must be tested at least once every year by an installer.
Temperature (operating)	Functional range: -10°C to +49°C (+14°F to +120°F) UL only: 0°C to +49°C (+32°F to +120°F)
Relative Humidity	0% to 93% (non-condensing)
Terminal block	For connecting other dry contact devices such as another magnetic reed switch.
Wall and cover tamper switch	Transmits a tamper signal when someone removes the device from its base or pulls it away from the wall.
Frequency	433.42 MHz

Table 15.1: Specifications

Single EOL Resistor Option

Use a 2.2 k Ω EOL resistor. Refer to the diagram below.

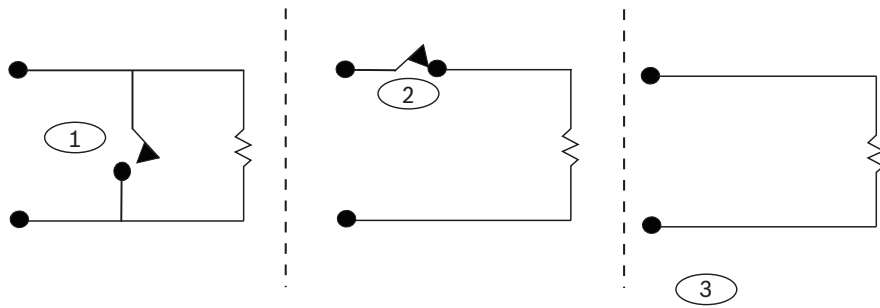

Figure 15.1: Single EOL resistor option

Callout - Description
1 - Normally-open (NO)
2 - Normally-closed (NC)
3 - Input disabled - no contact

15.1 Installation considerations

You have a variety of installation options to consider when installing the device. You must acknowledge the unique installation approach prior to installation. Some installation considerations include:

- The location of the magnet and transmitter in relationship to the door/window frame dimensions. Verify you have proper clearance with the latch of the window or door you are installing the device onto. Failure to do so will make it extremely difficult to access and open the device for maintenance purposes.
- In some cases, you might need an additional spacer when installing the transmitter and magnet in the corner of a recessed door or window frame to close the gap in height between the magnet and transmitter.
- On surface areas that are not conducive to mounting via the screws, you can secure transmitters and magnets using an industrial strength adhesive.
- When installing the magnet, verify that the notches in the magnet base, line up with the notches in the transmitter base, otherwise the magnet and transmitter do not function effectively.
- When installing the magnet base, install the face of the magnet base flush to the surface edge of the installation location. This prevents damage to the magnet plastic base whenever a window or door is opened.
- Adhere to the distances prescribed in the graphical table found in the graphical *Installation and Operation Guide* when installing the magnet adjacent to the transmitter.

How to read the Graphical Magnet Distances table

Contained in the universal transmitter *Installation and Operation Guide* is a graphical table along with the X -Y-Z coordinates graphic. Use the table in conjunction with the graphic to determine desired distances between the magnet and the transmitter based on the type of installation (wood or metal).



Notice!

The content in the graphical table applies to EN installations.

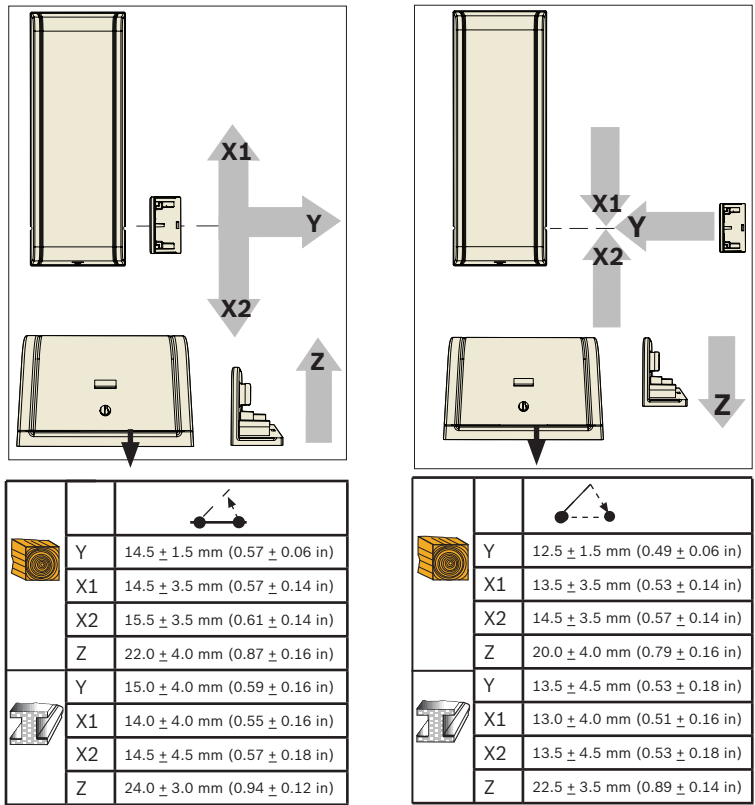

15.2 Reed switch settings

Set the detector to enable or disable the reed switch.



Notice!

Please note, insert the jumper onto the pin prior to installing the battery. Failure to do so may result in unexpected operation of the device.

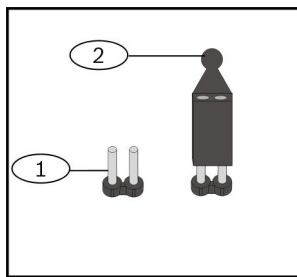

Figure 15.2: Reed switch

Callout - Description

1 - No jumper disables the internal reed switch

2 - Jumper on enables the internal reed switch

16 RADION keyfob (all RFKFs)

RADION keyfobs (two button and four button) are personal transmitters carried by the user that allow the user to remotely arm or disarm a security area.



Notice!

RADION encrypted keyfobs

Use of the RADION encrypted keyfobs requires use of RADION receivers having the latest firmware version. Refer to the following tables for compatible receiver firmware versions.

Encrypted keyfobs	Non-encrypted keyfobs
RFKF-FBS-A	RFKF-FB-A
RFKF-TBS-A	RFKF-TB-A
RFKF-FBS	RFKF-FB
RFKF-TBS	RFKF-TB
RFKF-FBS-CHI	RFKF-FB-CHI
RFKF-TBS-CHI	RFKF-TB-CHI

Item	Specification
Dimensions	63.70 mm x 35.50 mm x 13.00 mm (2.51 in x 1.40 in x 0.51 in)
Power/voltage	One Lithium battery (CR2032) 3 VDC Power source type: C Low battery level: 2.1V
Battery replacement	Panasonic CR2032, Duracell DL2032. Check your Battery yearly to ensure proper functionality
Battery life	Up to 5 years
Temperature (operating)	Functional range: -10°C to +49°C (+14°F to +120°F) UL only: 0°C to +49°C (+32°F to +120°F)
Relative humidity	0% to 93% (non-condensing)
Frequency	433.42 MHz

Table 16.1: Specifications

**Notice!**

Please note, the battery does not come installed. Refer to the specification table for the correct battery type when replacing an old battery.

Keyfob buttons

Refer to your control panel's documentation to program the functions of the programmable buttons. Pressing either the arm or disarm button causes the LED to flash for about 2 sec., indicating the keyfob sent commands to the control panel.

**Notice!**

Pressing the Arm and Disarm buttons in unison for 1 sec transmits a panic alarm.

16.1**RADION keyfob FB (four button)**

The RADION keyfob FB four button keyfobs are designed for arming (lock icon) and disarming (unlock icon) the system remotely. You can configure the programmable buttons at the control panel for additional control functionality. To operate the programmable buttons, simply press and hold either button for at least one sec in order for the desired feature to work.

- Uniquely coded arm and disarm buttons
- Panic alarm
- LED indicator
- Programmable option buttons

The RKFf-FBS-CHI keyfob includes synchronized encryption and is compatible only with RADION receivers having firmware v1.3 or higher.

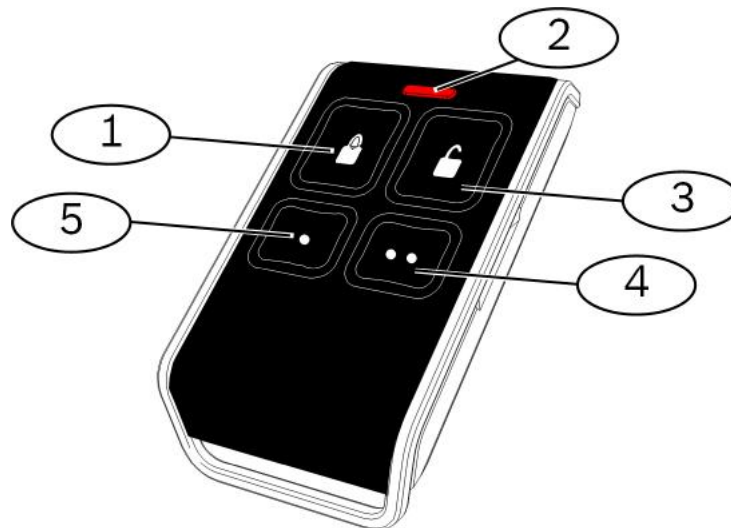

Figure 16.1: Keyfob buttons and LED

Callout - Description
1 - Arm button
2 - LED

Callout - Description
3 - Disarm button
4 - Programmable button
5 - Programmable button

16.2 RADION keyfob TB (two button)

The RADION keyfob TB two button keyfobs are designed for arming (lock icon) and disarming (unlock icon) the system remotely. To operate these buttons, simply press and hold either button for at least one sec in order for the desired feature to work.

- Uniquely coded arm and disarm buttons
- Panic alarm
- LED indicator

The RKFf-TBS-CHI keyfob includes synchronized encryption and is compatible only with RADION receivers having firmware v1.3 or higher.

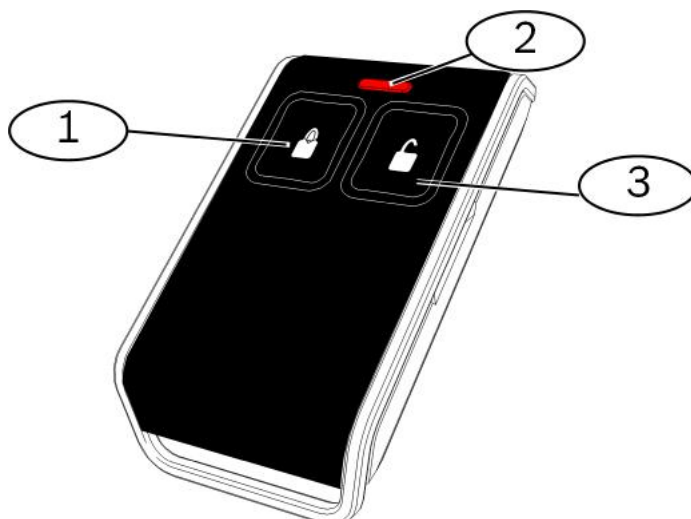

Figure 16.2: Keyfob buttons and LED

Callout - Description
1 - Arm button
2 - LED
3 - Disarm button

17

RADION panic (RFPB)

The RADION panic is a transmitter that sends a panic alarm signal to the security system when one (single button panic), or both panic buttons (2-button panic) are pressed for 1 sec. The single-button, or two-button panic transmitter can be used in a variety of options such as a pendant, wrist strap, belt clip, depending on the desired accessory.



Notice!

To achieve optimal RF range performance, the RADION panic should be activated while held in the hand, and not mounted to a fixed surface

The RADION panic offers the following features:

- Each transmitter has a unique code
- Panic alarm signal
- One or two button versions
- LED indicator
- Optional accessories

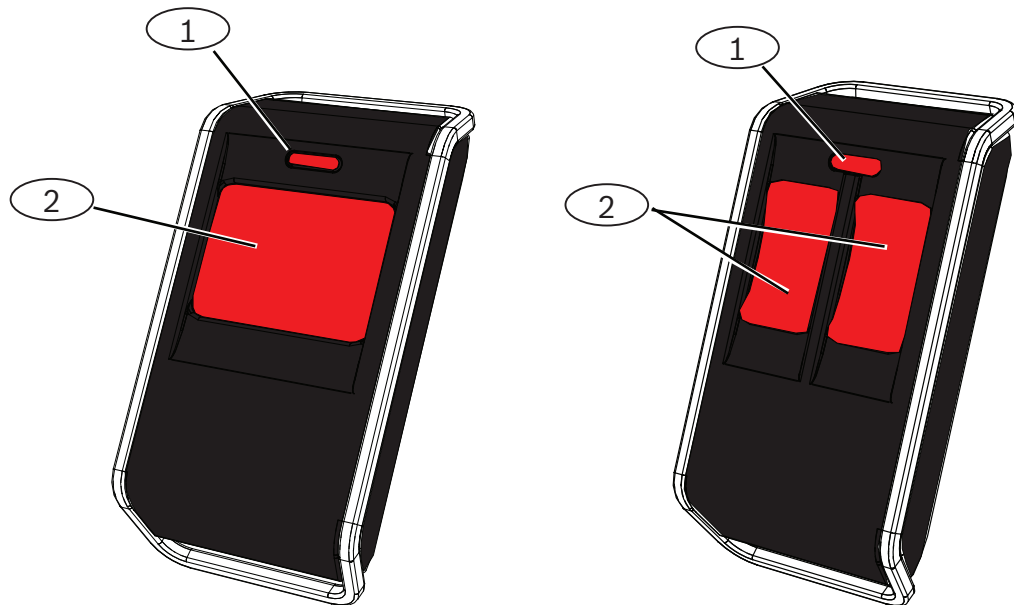

Figure 17.1: Panic Buttons

Callout - Description
1 - Panic buttons
2 - LED

Relative humidity	0% to 93% (non-condensing)
Temperature (operating)	Functional range: -10°C to +49°C (+14°F to +120°F) UL only: 0°C to +49°C (+32°F to +120°F)
Dimensions	63.70 mm x 35.50 mm x 13.00 mm (2.51 in x 1.40 in x 0.51 in)
Power/voltage	One CR2032 Lithium battery, 3 VDC Power source type: C

Relative humidity	0% to 93% (non-condensing)
	Low battery level: 2.1V
Battery replacement	Panasonic CR2032, Duracell DL2032. Check your Battery yearly to ensure proper functionality
Battery life	Up to 5 years
LED	Red
Frequency	433.42 MHz

Table 17.1: Specifications

**Notice!**

Please note, the battery does not come installed. Verify that the correct battery as defined in the specification table is installed in the proper polarity.





Optional Accessories	
Pendant	Pendant transmitters provide single or two-button activation confirmed by emitting LED flashes with all transmissions to clearly show users when the unit is operating. Users can wear the pendants on a neck cord. The pendants are ideal to meet the needs of patrolling guards, bank employees, and retail store employees.
Belt Clip	Belt Clip transmitters provide single or two-button activation confirmed by emitting LED flashes with all transmissions to clearly show users when the unit is operating. The single-button design is ideal for assisted living installations whereas the two-button design reduces accidental activation.
Wrist Strap	Wrist Strap transmitters provide single or two-button activation confirmed by emitting LED flashes with all transmissions to clearly show users when the unit is operating.







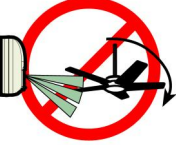
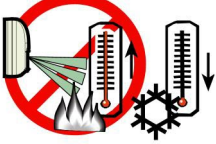
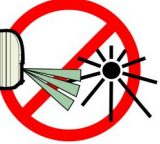
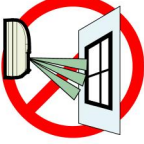
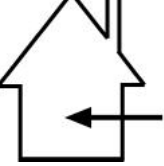

18

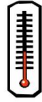

Appendices

Icons and symbols

Use the table below for descriptions of the icons and symbols used in the reference guide.

Description	Icon/symbol
Not pet friendly.	
Signifies that the item is the correct choice, selection, or location.	
Pet friendly (appropriate height and weights below graphic).	
Point away from rotating machines.	
Point away from objects that rapidly change temperature	
Do not mount the device that has direct exposure to sunlight.	
Do not point toward window.	
Intended for indoor use only.	
Electrostatic discharge symbol	

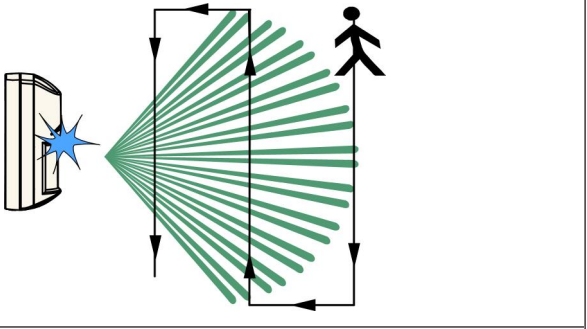
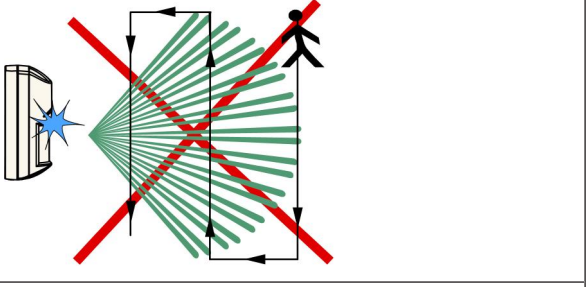
<p>Symbol against disposing batteries into the garbage</p>	
<p>Humidity range</p>	
<p>Temperature range</p>	
<p>Frequency range</p>	
<p>Duration of time</p>	
<p>Questions are answered in the reference guide.</p>	
<p>Universal sign for connecting or disconnecting power.</p>	
<p>Universal sign for connecting to a power source.</p>	
<p>Battery-related information.</p>	

<p>Perform a walk test</p>	
<p>Walk test has concluded</p>	
<p>Device has wall tamper detection.</p>	

Bosch Security Systems B.V.

Torenallee 49

5617 BA Eindhoven

Netherlands

www.boschsecurity.com

© Bosch Security Systems B.V., 2025

Building solutions for a better life

202507181406