

# DHI-HY-LD413A-P

## Termination Unit



### System Overview

DHI-HY-LD413A-P Termination Unit is used together with DHI-HY-LD413A-I Adaptor Unit, which can be matched with conventional, outdoor anti-corrosive and explosion-proof shielded temperature sensing cables. It is used to balance the signal status and has test keys for fire alarm and fault.

### Functions

#### Stable performance

Accurate detection and strong anti-false alarm capability.

#### Reliable protection

With metal material, it is resistant to blows, falls and shocks.

#### Convenient installation

Wall mount, easy to install.

#### Wide range of adaptability

Matched with a variety of cables, to adapt to the different scenes and temperatures.

### Scene

It is suitable for the cable bridge, transformer temperature detection, conveyor belt temperature detection in coal mining industry, petrochemical storage tanks, reaction vessel temperature detection and other industries.

### Technical Specification

Length	≤ 500m
Cable Temperature	68°C, 88°C, 105°C, 138°C
Operating Temperature	-45°C to +60°C (-49°F to +140°F)
Operating Humidity	≤ 95% RH (no condensation)
Protection	IP66
Material	Aluminum
Dimensions	127 mm × 85 mm × 58 mm (5" × 3.35" × 2.28")
Weight	350 g (0.77 lb)

Dimensions (mm/inch)

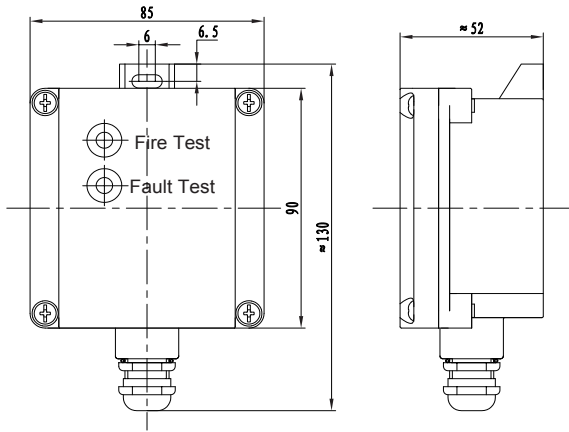

Ordering Information

Type	Part Number	Description
Accessories	DHI-HY-LD413A-P	Termination Unit