

Smart Network Video Recorder

Quick Start Guide

V1.0.0



1-2.51.50.U10492-000

- English** Scan the QR code on the cover to get multilingual quick start guides.
- Deutsch** Scannen Sie den QR-Code auf dem Umschlag für mehrsprachige Schnellstartanleitungen.
- Français** Analysez le code QR sur la couverture pour consulter les guides de démarrage rapide en d'autres langues.
- Nederlands** Scan de QR-code op de omslag voor meertalige snelstartgidsen.
- Español** Escanee el código QR en la cubierta para acceder a las guías de inicio rápido multidioma.
- Português** Faça a leitura do código QR na parte inferior do dispositivo para obter os guias de início rápido em várias línguas.
- Italiano** Scansionare il codice QR sulla copertina per ottenere le guide rapide multilingue.
- Polski** Zeskanuj kod QR na osłonie, aby wyświetlić skróconą instrukcję obsługi w wielu językach.
- Türkçe** Çok dilli hızlı başlangıç kılavuzlarını almak için kapaktaki karekodu tarayın.
- Svenska** Skanna QR-koden på omslaget för flerspråkiga snabbstartguider.
- Dansk** Scan QR-koden på omslaget for at få en kvikstartguide på flere sprog.
- Norsk** Skan QR-koden på dekslet for å få flerspråklige hurtigstartguider.
- Suomi** Löydät monikielisiä pika-aloitusoppaita skannaamalla kannessa olevan QR-koodin.
- Čeština** Po naskenování QR kódu na krytu získáte vícejazyčné stručné návody k použití.
- Slovenčina** Naskenujte QR kód na obale a získajte viacjazyčných rýchlych sprievodcov.
- Srpski** Skenirajte QR kod na omotu da biste pristupili višejezičnim sažetim vodičima za računalnike.
- Română** Scanați codul QR de pe capac pentru ghiduri de pornire în mai multe limbi.
- magyar** A borítón található QR-kód beolvasásával elérhetővé válnak a többnyelvű gyorstájékoztatók.

- Latviešu** Skenējiet QR kodu uz vāka, lai piekļūtu vairāku valodu ātrās palaišanas rokasgrāmatām.
- Eesti** Kaanel oleva QR-koodi skaneerimisega näete mitmekeelseid kiirjuhendeid.
- Lietuvių** Norėdami gauti daugiakalbius greitojo naudojimo vadovus, nuskaitykite ant viršelio esantį QR kodą.
- Ελληνικά** Σκάνωστε τον QR κωδικό στο εξώφυλλο για πολύγλωσσους οδηγούς γρήγορης εκκίνησης.
- Българска** Сканирайте QR кода на корицата, за да получите многоезични ръководства за бързо стартиране.
- Slovenščina** Za večjezične hitre vodnike skenirajte QR kodo na ovitku.
- Hrvatska** Skenirajte QR kod na omotu kako biste dobili višejezične vodiče za brzo pokretanje.
- ภาษาไทย** สแกนรหัส QR บนฝาครอบเพื่อรับคู่มือเริ่มต้นใช้งานฉบับย่อหลายภาษา
- Tiếng Việt** Quét mã QR trên trang bìa để xem hướng dẫn khởi động nhanh bằng nhiều ngôn ngữ.
- Bahasa Indonesia** Pindai kode QR di penutup untuk mendapatkan panduan mulai cepat multibahasa.
- Bahasa Melayu** Imbas kod QR pada muka hadapan untuk mendapatkan panduan permulaan ringkas berbilang bahasa.
- العربية** يرجى مسح رمز الاستجابة السريعة (QR) الموجود على الغطاء للوصول إلى أدلة البدء السريع المتوفرة بعدة لغات. تمت الترجمة بواسطة شركة MarsHub CO.,Ltd. (رقم الشهادة: TMS10662220GZ) 17100
- 한국어** 커버의 QR 코드를 스캔하여 다국어 빠른 시작 가이드를 받아보십시오.
- 日本語** 表紙のQRコードをスキャンすると、多言語のクイックスタートガイドをご覧ください。
- Українська** Відскануйте QR-код на обкладинці, щоб отримати короткі посібники на декількох мовах.
- Русский** Отсканируйте QR-код на обложке, чтобы получить многоязычные руководства по быстрому запуску.
- বাংলা** বহুভাষায় কুইক স্টার্ট গাইডসমূহ পতে কভারের QR কোডটি স্ক্যান করুন।

Safeguards and Warnings

- The device should not be wall-mounted with the front panel facing down. Please install it horizontally or in a stable location to prevent it from falling.
- Do not install the device in areas that are damp, dusty, or smoky.
- Keep liquids away from the device to avoid spills or splashes. Do not place any items filled with liquid on or around the device.
- Ensure adequate airflow around the device by installing it in a well-ventilated area and keeping the air vents unblocked.
- Do not disassemble the device without proper authorization or guidance.
- Always transport, use, and store the device within the allowed humidity and temperature limits.
- For device safety, connect it to the power adapter prior to plugging adapter into the electrical outlet. Once all connections are secured, turn on the power switch, if available.
- Refrain from placing or installing the device in direct sunlight or near heat sources.
- The device is designed to operate within the specified input/output range, requiring a power supply of 12VDC 2 A. Please use the supplied power adapter if included.

Get Detailed User Manual

For a detailed user manual, customer support hotline and additional services, please scan the QR code below or visit <https://www.imou.com/support>.



01 Package Contents

- NVR x1
- Power Adapter x1
- Mouse x1
- SATA Power Cable x1
- SATA Data Cable x1
- Ethernet Cable x1
- Screw Pack x1
- Quick Start Guide x1
- Regulatory Information x1

02 Overview

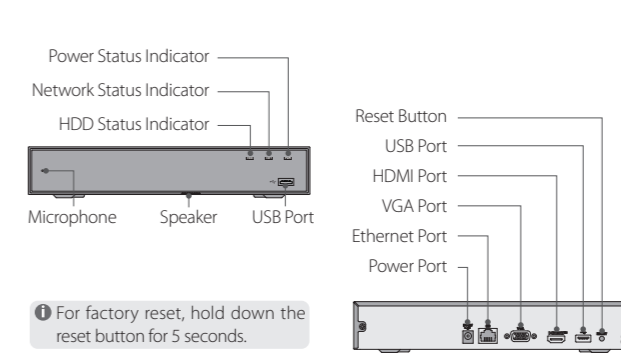

i For factory reset, hold down the reset button for 5 seconds.

Indicator	Status	Meaning
HDD	Off	Hard drive functions properly
	Solid red	Hard drive abnormality
NET	Off	Wired network connection is normal
	Solid red	Wired network connection error
PWR	Off	Power connection error
	Solid green	Power is connected

03 Hard Drive Installation

- Please prepare a 3.5-inch mechanical hard disk drive. Before installation, disconnect the NVR from the power.
- Remove four screws on the side and rear of the upper cover.
- Carefully lift the cover away.

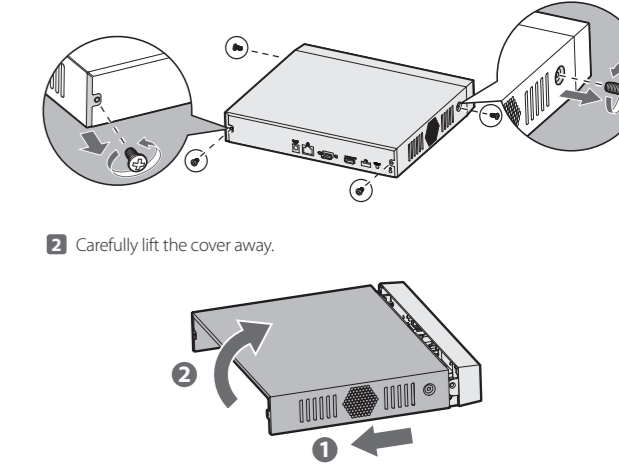

- 3** Plug in the data and power cables into their respective connectors on the hard drive and NVR.

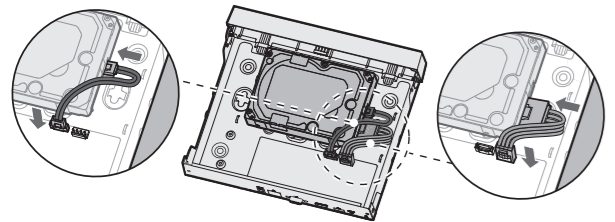

- 4** Flip over the NVR. Align the hard drive with the four screw holes at the bottom of the NVR and secure it with provided screws.

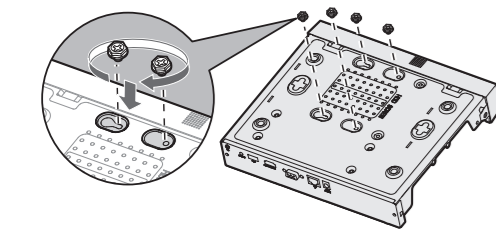

- 5** Replace the cover.

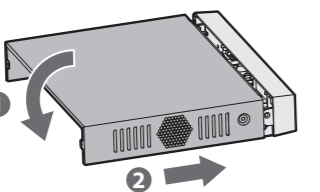

- 6** Fasten the cover using previously removed screws.

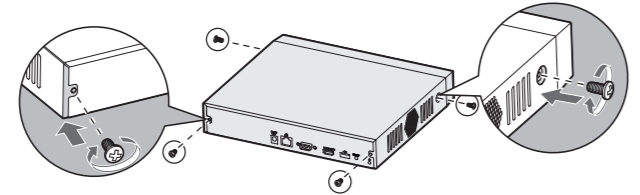

04 Connection

Instructions below are for cameras connected to the NVR via wire.

- i** If you have multiple wired cameras, it is recommended to connect them to a switch and connect the switch to a router.

- 1** Finish all physical connections, then power on the cameras and the NVR.

- 2** For wired cameras that are newly added, they will automatically connect to the NVR. To start, right-click on the NVR's live view and navigate to **Main Menu > Camera > Add Devices > Search Devices**. Remain on this interface and wait for the connection to complete. Successfully connected cameras (marked with green dots) will appear in the lower list. If the connection fails, click the **Search Devices** button, then double-click the detected device to add it.

- If the wired camera is not on the same network segment as the NVR, click **✖** to modify its IP address after being manually detected.
- For the camera with different username and password than the NVR, click **✖** to re-enter its own credentials after it is added.

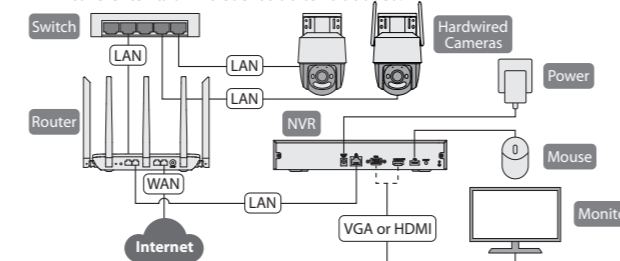

05 Basic NVR Operations

- ⚠** During upgrade of the NVR or its connected cameras, keep all devices powered throughout the process.

1 Power On and Off

- **Power On:** Connect a monitor to the NVR and plug it in using the provided power adapter to turn it on.
- **Shut Down:** Enter the "Main Menu", click **⏻** in the upper-right corner, and select "Shutdown." Unplug the power once the screen goes black. Do not disconnect the device from power while data is being saved or video recording is in progress.

2 Device Initialization

For first use, the device will undergo initialization, which include creating a password for the default user admin, filling in the answers used for password reset, etc.

3 Startup Wizard

The startup wizard will guide you through quick settings of the NVR, such as IP parameters, update issues and HDD management.

4 Live View

Once the camera is connected to the NVR, you can view its live streams in various layouts. Hover over the floating toolbar to access different functions.

5 Video Playback

Right-click on the live view interface and select "Playback" to check recorded video clips which can be filtered by dates, recording types, etc.

06 Access NVR via Imou Life App

- 1** Scan the QR code below or search for "Imou Life" in the app store to install the app. Create an account and log in.

- i** If you already have the app, ensure it is up-to-date.



- 2** Launch the app. On the home page, tap + in the upper-right corner to scan the QR code at the bottom of the device. Follow on-screen instructions to finish the setup. Then you can view live streams, video recordings or event clips of connected devices.

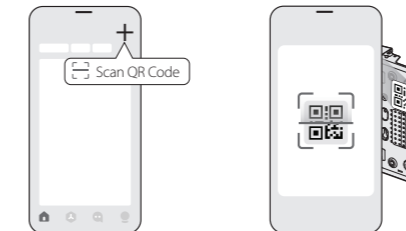

07 FAQ

Q: The NVR won't start properly?

A: Check the power indicator light (PWR) on the front panel. If the light is off, ensure the power cable is securely connected to the NVR and the outlet is functioning. If the indicator lights up green, verify the display's power and video cables are firmly seated at both ends. If issues persist, please contact our technical support.

Q: Failed to add the camera to the NVR?

A: Directly connect the camera to NVR's Ethernet port, then reset the camera. After the camera reboots, right-click on the live view, and go to **Main Menu > Camera > Add Devices > Search Devices**. Click **Search Devices** button. If the camera can be detected, check if both the camera and NVR were on the same network segment range before.

Q: How to add third-party cameras to NVR?

A: Wired connections for third-party cameras are recommended. Ensure they are on the same network segment as the NVR. Try either method below.

- Add by manual search: Right-click on the live view. Go to **Main Menu > Camera > Add Devices > Search Devices**. Click **Search Devices** button. Double-click the detected camera to add it. Once added, modify the camera's username and password by clicking **✖** and save changes.
- Add by information entry: Right-click on the live view. Go to **Main Menu > Camera > Add Devices > Search Devices**. Click **Manual Add** button. Select **Onvif** as the protocol, enter camera's IP address and password, then click **OK**.

Q: What to do if the live streaming lags after the camera has been connected to the NVR?

A: Directly connect the camera to NVR's Ethernet port. If the stream stabilizes, inspect the Ethernet cable and router/switch to ensure they are capable of high-speed transmission.

Q: No recordings available for playback?

A: Check the hard drive indicator light (HDD) on the front panel. If it glows red, follow the steps below to verify:

1. Inspect cable connections: Check if HDD's power and data cables are properly connected and secure.
2. Verify HDD status: Look for "No HDD" or "HDD error" alerts in the upper-left corner of the live interface, or right-click on the live view and navigate to **Main Menu > Storage > HDD Manager** to check the drive's status. Replace it if there are any abnormalities.

Q: How to add the NVR to Imou Life App?

- A:**
- Option 1: Refer to previous section "06 Access NVR via Imou Life App."
 - Option 2:

1. Right-click on the live view. Navigate to **Main Menu > Network > Cloud Services** (keep it open for later use). Ensure you have turned on **Cloud Services** and the NVR has an active Internet connection; otherwise you may fail to add the NVR to the app.
2. Install the Imou Life app by scanning the left **Cellphone Client QR code** on the **Cloud Services** interface with your smartphone.
3. To add the NVR to the app, launch the app and log in. Tap **+** in the upper-right corner and scan **Net Config QR Code** (the right one) from NVR's **Cloud Services** interface.
4. Live view and device management: Once added, access the NVR from app's homepage. Tap **Bind All**, and all cameras connected to the NVR will be available for live monitoring and setting adjustments via the app.

If you need any assistance, feel free to reach us at service.global@imou.com. For more information about Imou, please visit www.imou.com.